



Agilent 75000 SERIES B

Agilent E1361A 4X4 Relay Matrix Module

User's Manual



Copyright© Agilent Technologies, Inc., 2006



E1361-90002
E0406

Contents

Agilent E1361A 4X4 Relay Matrix Module

Warranty	5
WARNINGS	6
Safety Symbols	6
Declaration of Conformity	7
Reader Comment Sheet	9
Chapter 1. Getting Started	11
Using This Chapter	11
Instrument Definition	11
Matrix Description	11
Basic Operation	12
Typical Configuration	13
Programming the Matrix	13
Specifying SCPI Commands	13
Initial Operation	15
Chapter 2. Configuring the Agilent E1361A Relay Matrix	17
Using This Chapter	17
Warnings and Cautions	17
Connecting User Inputs	18
Typical Matrix Configurations	20
4 X 4 Matrix Configuration	20
Dual 4 X 2 Matrix Configuration	20
Building Larger Matrixes	21
High-Voltage Matrix Configuration	22
Changing Matrix Module Components	22
Connecting User Inputs	24
Chapter 3. Using the Agilent E1361A Relay Matrix	25
Using This Chapter	25
Relay Matrix Commands	25
Switching Channels	25
Example: 4 X 4 Matrix Switching	26
Example: Dual 4 X 2 Matrix Switching	26
Switching Channels Comments	27
Chapter 4. Understanding the Relay Matrix	29
Using This Chapter	29
Scanning Channels Commands	29
Using Scanning Trigger Sources	29
Scanning With External Instruments	29
Example: Scanning with External Device	32
Example: Scanning Using Trig Out and Event In Ports	33

Chapter 4. Understanding the Relay Matrix (continued)	
Using the Scan Complete Bit	34
Special 488.2 Commands	35
Storing States	35
Recalling States	35
Response to *RST	35
SCPI Error Responses	35
Chapter 5. Agilent E1361A Relay Matrix Command Reference	37
Using This Chapter	37
Command Types	37
Common Command Format	37
SCPI Command Format	38
Command Separator	38
Abbreviated Commands	38
Implied Commands	38
Parameters	39
Linking Commands	40
SCPI Command Reference	40
ABORt	41
ARM	42
:COUNT	42
:COUNT?	43
DISPlay	44
MONitor:CARD	44
MONitor[:STATe]	45
INITiate	46
:CONTinuous	46
:CONTinuous?	47
[:IMMediate]	47
OUTPut	48
[:STATe]	48
[:STATe]?	48
[ROUte:]	49
CLOSE	49
CLOSE?	50
OPEN	50
OPEN?	51
SCAN	51
SCAN:MODE	52
SCAN:MODE?	52
STATus	53
:OPERation:ENABle	53
:OPERation[:EVENT]?	53
SYSTem	54
:CDEscription?	54
:CPON	54
:CTYPe?	55

Chapter 5. Agilent E1361A Relay Matrix Command Reference (continued)

SYSTEM (continued)	
:ERRor?	55
TRIGger	56
[:IMMediate]	56
:SOURce	57
:SOURce?	58
IEEE 488.2 Common Commands	59
Command Quick Reference	60
Appendix A. Agilent E1361A Relay Matrix Specifications	61
Relay Life	62
Appendix B. Agilent E1361A Relay Matrix Registers	63
Register Definitions	63
Addressing the Registers	64
Reading the Registers	64
ID/Device Type Registers	64
Status/Control Register	64
Channel Enable Register	64
Writing to the Registers	65
Status/Control Register	65
Channel Enable Register	65
Appendix C. Agilent E1361A Relay Matrix Error Messages	67

Notes

Certification

Agilent Technologies certifies that this product met its published specifications at the time of shipment from the factory. Agilent Technologies further certifies that its calibration measurements are traceable to the United States National Institute of Standards and Technology (formerly National Bureau of Standards), to the extent allowed by that organization's calibration facility, and to the calibration facilities of other International Standards Organization members.

Warranty

This Agilent Technologies product is warranted against defects in materials and workmanship for a period of one year from date of shipment. Duration and conditions of warranty for this product may be superseded when the product is integrated into (becomes a part of) other Agilent products. During the warranty period, Agilent Technologies will, at its option, either repair or replace products which prove to be defective.

For warranty service or repair, this product must be returned to a service facility designated by Agilent Technologies. Buyer shall prepay shipping charges to Agilent and Agilent shall pay shipping charges to return the product to Buyer. However, Buyer shall pay all shipping charges, duties, and taxes for products returned to Agilent from another country.

Agilent warrants that its software and firmware designated by Agilent for use with a product will execute its programming instructions when properly installed on that product. Agilent does not warrant that the operation of the product, or software, or firmware will be uninterrupted or error free.

Limitation Of Warranty

The foregoing warranty shall not apply to defects resulting from improper or inadequate maintenance by Buyer, Buyer-supplied products or interfacing, unauthorized modification or misuse, operation outside of the environmental specifications for the product, or improper site preparation or maintenance.

The design and implementation of any circuit on this product is the sole responsibility of the Buyer. Agilent does not warrant the Buyer's circuitry or malfunctions of Agilent products that result from the Buyer's circuitry. In addition, Agilent does not warrant any damage that occurs as a result of the Buyer's circuit or any defects that result from Buyer-supplied products.

NO OTHER WARRANTY IS EXPRESSED OR IMPLIED. Agilent SPECIFICALLY DISCLAIMS THE IMPLIED WARRANTIES OF MERCHANTABILITY AND FITNESS FOR A PARTICULAR PURPOSE.

Exclusive Remedies

THE REMEDIES PROVIDED HEREIN ARE BUYER'S SOLE AND EXCLUSIVE REMEDIES. Agilent SHALL NOT BE LIABLE FOR ANY DIRECT, INDIRECT, SPECIAL, INCIDENTAL, OR CONSEQUENTIAL DAMAGES, WHETHER BASED ON CONTRACT, TORT, OR ANY OTHER LEGAL THEORY.

Notice

The information contained in this document is subject to change without notice. Agilent Technologies MAKES NO WARRANTY OF ANY KIND WITH REGARD TO THIS MATERIAL, INCLUDING, BUT NOT LIMITED TO, THE IMPLIED WARRANTIES OF MERCHANTABILITY AND FITNESS FOR A PARTICULAR PURPOSE. Agilent shall not be liable for errors contained herein or for incidental or consequential damages in connection with the furnishing, performance or use of this material. This document contains proprietary information which is protected by copyright. All rights are reserved. No part of this document may be photocopied, reproduced, or translated to another language without the prior written consent of Agilent Technologies, Inc. Agilent assumes no responsibility for the use or reliability of its software on equipment that is not furnished by Agilent.

U.S. Government Restricted Rights

The Software and Documentation have been developed entirely at private expense. They are delivered and licensed as "commercial computer software" as defined in DFARS 252.227- 7013 (Oct 1988), DFARS 252.211-7015 (May 1991) or DFARS 252.227-7014 (Jun 1995), as a "commercial item" as defined in FAR 2.101(a), or as "Restricted computer software" as defined in FAR 52.227-19 (Jun 1987)(or any equivalent agency regulation or contract clause), whichever is applicable. You have only those rights provided for such Software and Documentation by the applicable FAR or DFARS clause or the Agilent standard software agreement for the product involved.

Agilent E1361A 4X4 Relay Matrix Module User's Manual
Edition 2 Rev 2

Copyright © 1995-2006 Agilent Technologies, Inc. All Rights Reserved.

Printing History

The Printing History shown below lists all Editions and Updates of this manual and the printing date(s). The first printing of the manual is Edition 1. The Edition number increments by 1 whenever the manual is revised. Updates, which are issued between Editions, contain replacement pages to correct the current Edition of the manual. Updates are numbered sequentially starting with Update 1. When a new Edition is created, it contains all the Update information for the previous Edition. Each new Edition or Update also includes a revised copy of this printing history page. Many product updates or revisions do not require manual changes and, conversely, manual corrections may be done without accompanying product changes. Therefore, do not expect a one-to-one correspondence between product updates and manual updates.

Edition 1 (Part Number E1361-90001) September 1989
Edition 2 (Part Number E1361-90002) April 1995
Edition 2 Rev 2 (Part Number E1361-90002) April 2006

Safety Symbols



Instruction manual symbol affixed to product. Indicates that the user must refer to the manual for specific **WARNING** or **CAUTION** information to avoid personal injury or damage to the product.



Alternating current (AC).



Direct current (DC).



Indicates hazardous voltages.



Indicates the field wiring terminal that must be connected to earth ground before operating the equipment—protects against electrical shock in case of fault.

WARNING

Calls attention to a procedure, practice, or condition that could cause bodily injury or death.

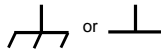

Frame or chassis ground terminal—typically connects to the equipment's metal frame.

CAUTION

Calls attention to a procedure, practice, or condition that could possibly cause damage to equipment or permanent loss of data.

WARNINGS

The following general safety precautions must be observed during all phases of operation, service, and repair of this product. Failure to comply with these precautions or with specific warnings elsewhere in this manual violates safety standards of design, manufacture, and intended use of the product. Agilent Technologies assumes no liability for the customer's failure to comply with these requirements.

Ground the equipment: For Safety Class 1 equipment (equipment having a protective earth terminal), an uninterruptible safety earth ground must be provided from the mains power source to the product input wiring terminals or supplied power cable.

DO NOT operate the product in an explosive atmosphere or in the presence of flammable gases or fumes.

For continued protection against fire, replace the line fuse(s) only with fuse(s) of the same voltage and current rating and type. DO NOT use repaired fuses or short-circuited fuse holders.

Keep away from live circuits: Operating personnel must not remove equipment covers or shields. Procedures involving the removal of covers or shields are for use by service-trained personnel only. Under certain conditions, dangerous voltages may exist even with the equipment switched off. To avoid dangerous electrical shock, DO NOT perform procedures involving cover or shield removal unless you are qualified to do so.

DO NOT operate damaged equipment: Whenever it is possible that the safety protection features built into this product have been impaired, either through physical damage, excessive moisture, or any other reason, REMOVE POWER and do not use the product until safe operation can be verified by service-trained personnel. If necessary, return the product to an Agilent Technologies Sales and Service Office for service and repair to ensure that safety features are maintained.

DO NOT service or adjust alone: Do not attempt internal service or adjustment unless another person, capable of rendering first aid and resuscitation, is present.

DO NOT substitute parts or modify equipment: Because of the danger of introducing additional hazards, do not install substitute parts or perform any unauthorized modification to the product. Return the product to an Agilent Technologies Sales and Service Office for service and repair to ensure that safety features are maintained.



Manufacturer's Name: Agilent Technologies, Incorporated
Manufacturer's Address: 815 – 14th St. SW
Loveland, Colorado 80537
USA

Declares, that the product

Product Name: 2 Wire 4x4 Relay Matrix
Model Number: E1361A
Product Options: *This declaration covers all options of the above product(s).*

Conforms with the following European Directives:

The product herewith complies with the requirements of the Low Voltage Directive 73/23/EEC and the EMC Directive 89/336/EEC (including 93/68/EEC) and carries the CE Marking accordingly.

Conforms with the following product standards:

EMC	Standard	Limit
	CISPR 11:1990 / EN 55011:1991	Group 1 Class A
	EN50082-1 :1992	
	IEC 1000-4-2 :1995	4kV CD, 8kV AD
	IEC 1000-4-3 :1995	3 V/m
	IEC 1000-4-4 :1995	0.5kV signal lines, 1kV power lines

Safety

The product was tested in a typical configuration with Agilent Technologies or Hewlett-Packard Company test systems

IEC 1010-1:1990+A2:1996 / EN 61010-1:1993
Canada: CSA C22.2 No. 1010.1:1992
UL 3111-1 : 1994

3 May 2001
Date

Ray Corson
Product Regulations Program Manager

For further information, please contact your local Agilent Technologies sales office, agent or distributor.
Authorized EU-representative: Agilent Technologies Deutschland GmbH, Herrenberger Strabe 130, D 71034 Böblingen, Germany

Notes

Notes

Notes

Using This Chapter

This chapter includes an Agilent E1361A Relay Matrix description, addressing guidelines, and an example program to check initial operation. Chapter contents are:

- Instrument Definition Page 11
- Matrix Description Page 11
- Programming the Matrix Page 13
- Initial Operation Page 15

Instrument Definition

Agilent plug-in modules installed in an Agilent mainframe are treated as independent instruments each having a unique secondary GPIB address. Each instrument is also assigned a dedicated error queue, input and output buffers, status registers and, if applicable, dedicated mainframe memory space for readings or data. An instrument may be composed of a single plug-in module (such as a counter) or multiple plug-in modules (for a switchbox or scanning voltmeter instrument).

Matrix Description

The Agilent E1361A 4 X 4 Relay Matrix module is a B-Size VXIbus and VMEbus register-based product which can be used for matrix switching or scanning. The matrix can operate in a B-Size VXIbus or VMEbus mainframe or (with an adapter) in a C-Size VXIbus mainframe.

The relay matrix consists of 16 latching relays (channels 00 through 15). The module is factory-configured as a 4 X 4 matrix. By removing jumpers, you can configure the module into a dual 4 X 2 matrix arrangement.

For the matrix, switching consists of closing a specified channel relay to provide row and column connections. Scanning consists of closing a set of relays, one relay at a time. You can open or close any combination of relays.

Basic Operation

Figure 1-1 shows simplified user connections for a matrix in the 4 X 4 configuration. To connect a specified row (0-3) to a specified column (0-3), close the relay at the crosspoint of the row and column. For example, close crosspoint relay 32 to connect row 3 to column 2. In the 4 X 4 matrix configuration, user row inputs can be to either Bank A or Bank B rows.

When a relay is closed, HIGH (H) and LOW (L) for the specified row and column are simultaneously connected. When a relay is opened the row/column inputs to the relay are disconnected. Since channel relays are latching, all relays remain in their current state during power-up or power-down. At reset, all relays are opened.

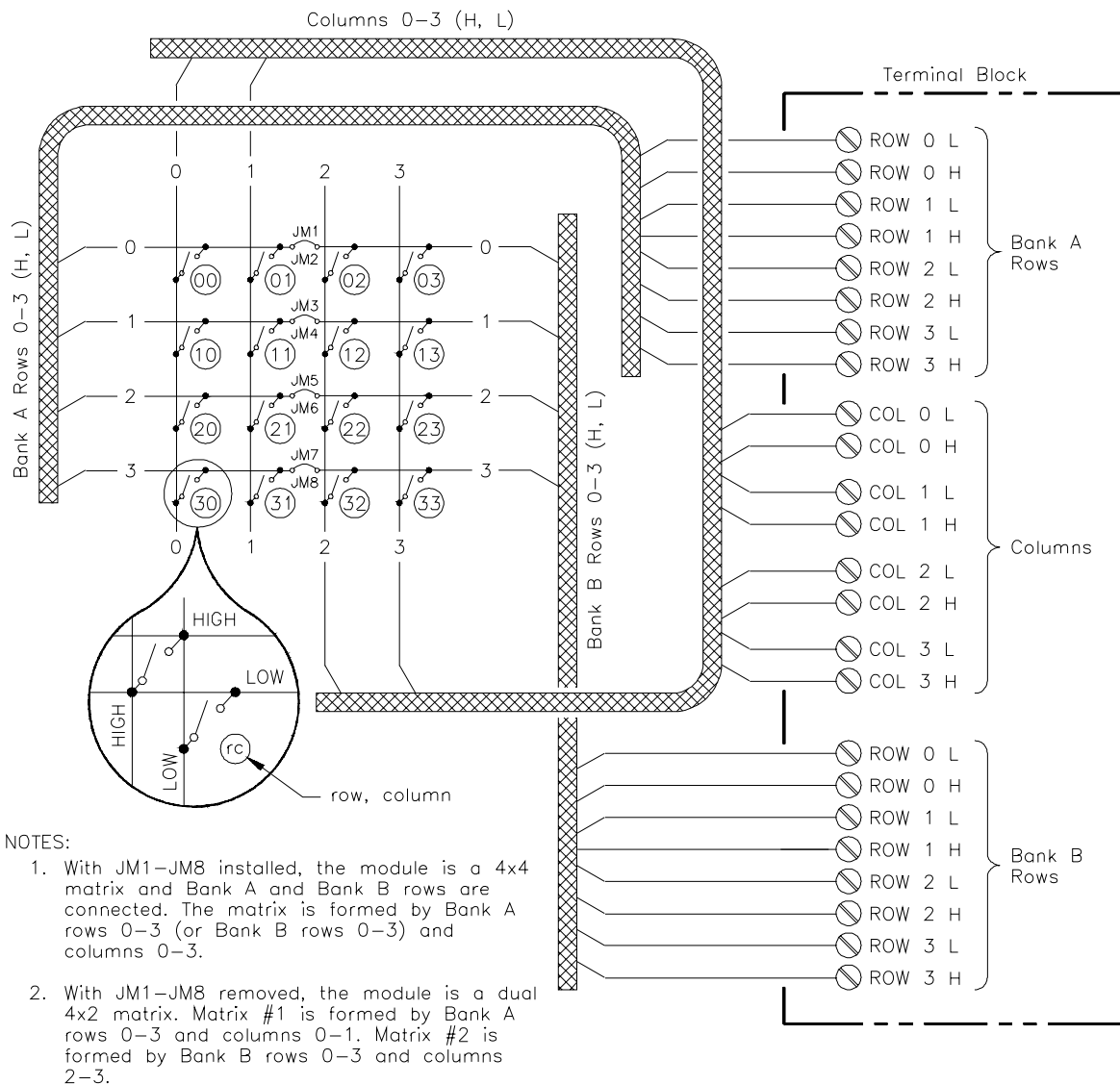

Figure 1-1. Relay Matrix Simplified Diagram

Typical Configuration

The relay matrix module accepts user inputs up to 250 V dc or 250 V ac RMS at 1 A dc or ac RMS (non-inductive). Maximum rated power capacity is 30 W or 40 VA per channel. Channel closure time is about 15 msec, so maximum scan rate is about 50 Hz.

As noted, the matrix may be configured for 4 X 4 or dual 4 X 2 matrix applications. For 4 X 4 matrix operation, no additional user configuration is required. To configure the matrix for dual 4 X 2 operation, you can remove factory-installed jumpers JM1 through JM8 (see Chapter 2 for jumper locations).

For a SCPI (Standard Commands for Programmable Instruments) environment, single or multiple relay matrixes can be configured as a *switchbox* instrument. For a switchbox instrument, all channels within the instrument can be addressed using a single interface address.

Programming the Matrix

To program the relay matrix using SCPI, you must select the computer language, interface address and SCPI commands to be used. Guidelines to select SCPI commands for the relay matrix follow. See the *Agilent 75000 Series B Installation and Getting Started Guide* for interface addressing and computer language information.

Note

This discussion applies only to SCPI (Standard Commands for Programmable Instruments) programming. See Appendix B, “Relay Matrix Registers” for information on relay matrix registers.

Specifying SCPI Commands

To address specific channels (relays) within a relay matrix, you must specify the SCPI command and matrix channel address. Use `CLOSe channel_list` to close specified relay(s); `OPEN channel_list` to open the relays; and `SCAN channel_list` to close the set of relays specified.

Matrix Channel Addresses

For the relay matrix, the channel address (*channel_list*) has the form (@nnrc) where nn = matrix card number (01-99), r = matrix row number (0-3), and c = matrix column number (0-3).

You can address single channels (@nnrc); multiple channels (@nnrc,nnrc,...); sequential channels (@nnrc:nnrc); groups of sequential channels (@nnrc:nnrc,nnrc:nnrc); or any combination.

Matrix Card Numbers

The matrix card number depends on the switchbox configuration (single-module or multiple-module) set for the matrixes. (Leading zeroes can be ignored for the card number.) For a single-module switchbox, the card number is always 01.

For a multiple-module switchbox, the card numbers are 01, 02,...,nn. The module with the lowest logical address is card number 01, the module with the next-lowest logical address is card number 02, etc. (See the appropriate *Installation and Getting Started Guide* for a definition of logical addresses.)

Example: Multiple-Module Switchbox Card Numbers

Assume the three relay matrixes in the following figure form a switchbox instrument with logical addresses of 120, 121, and 122. The module with the lowest logical address is card number 01. The card numbers are shown in the following figure.

Multiple – Multiplexer Switchbox Instrument

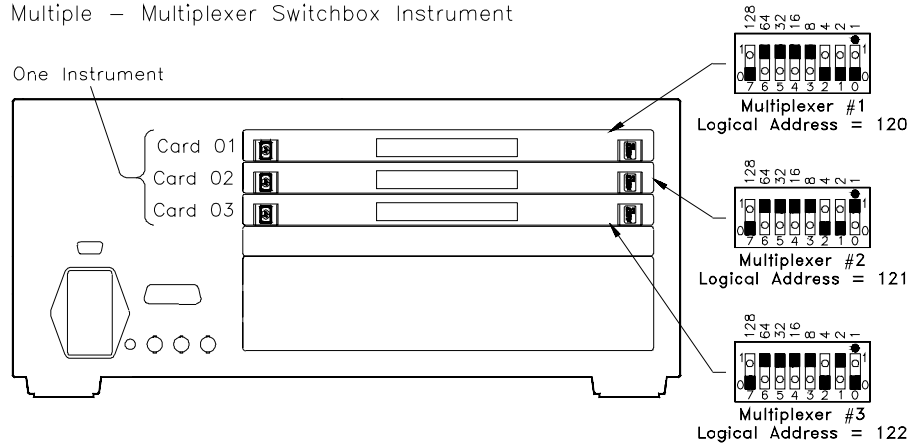

Matrix Channel Numbers

Relay matrix channel numbers are 00-03, 10-13, 20-23, and 30-33. Specifying a channel number specifies the associated crosspoint relay. For example, CLOS (@123) closes crosspoint relay 23 of card 01 which connects row 2 to column 3.

Channels can be addressed using channel numbers or channel ranges. For a single-module switchbox, channel ranges can span across the channels. For a multiple-module switchbox, channel ranges can span across the channels of all modules in the switchbox. Use commas (,) to form a channel list or use a colon (:) to form a channel range.

Only valid channels can be accessed in a channel list or channel range. Also, the channel list or channel range must be from a lower channel number to a higher channel number. For example, CLOS (@100:233) is acceptable, but CLOS (@233:100) generates an error.

Example: Relay Matrix Channel Lists/Ranges

Channel Lists:

CLOS (@100,112)	<i>Close relays 00 and 12 on card 01</i>
OPEN (@203,210)	<i>Open relays 03 and 10 on card 02</i>

Channel Ranges:

OPEN (@100:133)	<i>Open all relays on card 01</i>
SCAN (@100:133)	<i>Scan all relays on card 01</i>

Initial Operation

An example program follows which uses BASIC and SCPI language to get you started using the relay matrix. The example assumes an HP 9000 Series 200/300 controller and a General Purpose Interface Bus (GPIB). [GPIB is the implementation of the IEEE 488.2-1987 standard.]

The program closes channel 31 of a 4 X 4 relay matrix at logical address 120 (secondary address = $120/8 = 15$) to connect row 3 to column 1 and queries the result. The result is returned to the controller and displayed (1 = relay closed, 0 = relay open).

Example: Connect Row 3 to Column 1 (4 X 4 Matrix)

10 OUTPUT 70915;"CLOS (@131)"	<i>Connect row 3 to col 1</i>
20 OUTPUT 70915;"CLOS? (@131)"	<i>Query relay 31 state</i>
30 ENTER 70915;Value	<i>Enter result into Value</i>
40 PRINT Value	<i>Display result</i>
50 END	

Chapter 2

Configuring the Agilent E1361A Relay Matrix

Using This Chapter

This chapter shows how to make user connections to the relay matrix and some ways to configure the matrix module. Chapter contents are:

- Warnings and Cautions Page 17
- Connecting User Inputs Page 18
- Typical Matrix Configurations Page 20
- Changing Matrix Components..... Page 22

Warnings and Cautions

Warning **SHOCK HAZARD.** Only qualified, service-trained personnel who are aware of the hazards involved should install, configure, or remove the relay matrix. Use only wire rated for the highest input voltage and remove all power sources from the mainframe and installed modules before installing or removing a module.

Warning **CHANNEL WIRING INSULATION.** All channels that have a common connection must be insulated so that the user is protected from electrical shock in the event that two or more channels are connected together. This means wiring for all channels must be insulated as though each channel carries the voltage of the highest voltage channel.

Caution **MAXIMUM VOLTAGE/CURRENT.** Maximum allowable voltage per crosspoint relay for the relay matrix is 250 V dc or 250 V ac RMS (350 V ac peak). Maximum current per relay is 1 A dc or 1 A ac RMS (non-inductive). Maximum power input is 40 W (dc) or 40 VA (ac) per relay. Exceeding any limit may damage the relay matrix module.

Caution **STATIC-SENSITIVE DEVICE.** Use anti-static procedures when removing, configuring, and installing a module. The relay matrix is susceptible to static discharges. Do not install a matrix module without its metal shield attached.

Connecting User Inputs

The relay matrix consists of a component card and a terminal block. User inputs to the matrix are to the HIGH (H) and LOW (L) terminal connectors on the terminal block. Figure 2-1 shows the terminal block features and Figure 2-2 shows how to connect user (field) wiring to the terminal block.

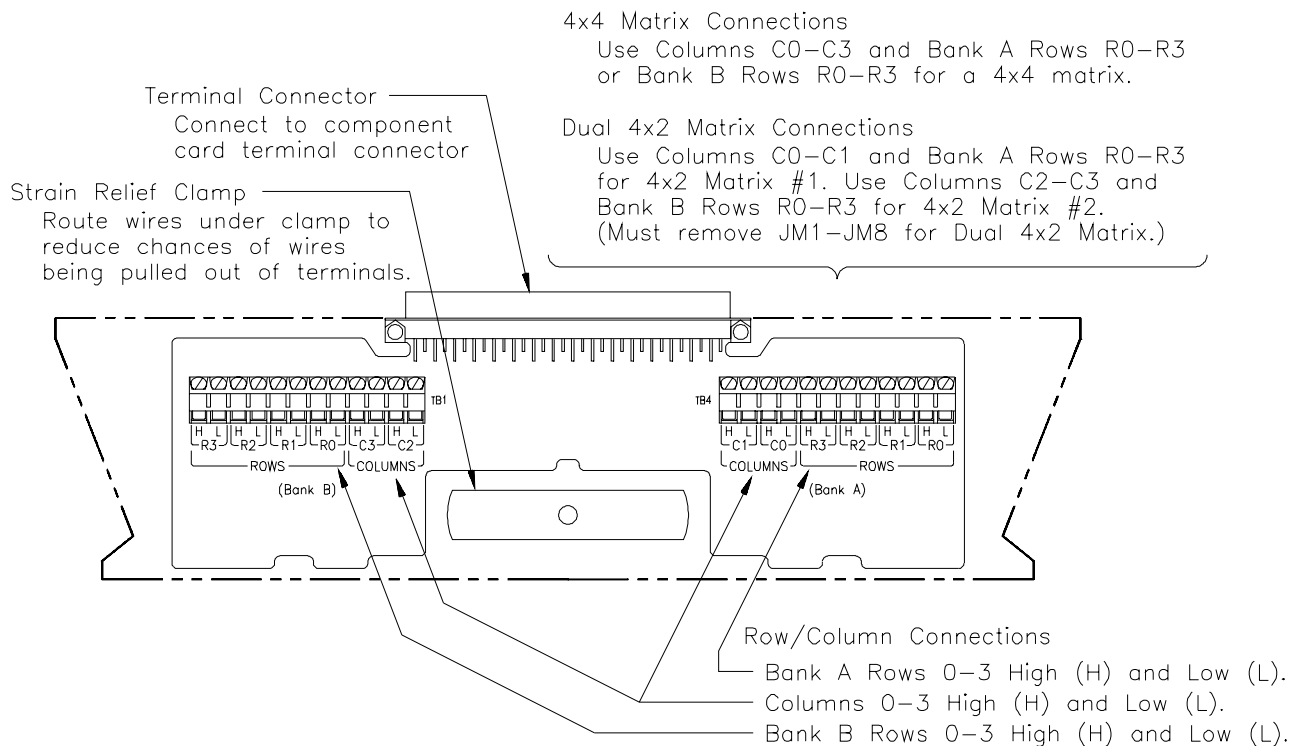

Figure 2-1. Relay Matrix Terminal Block

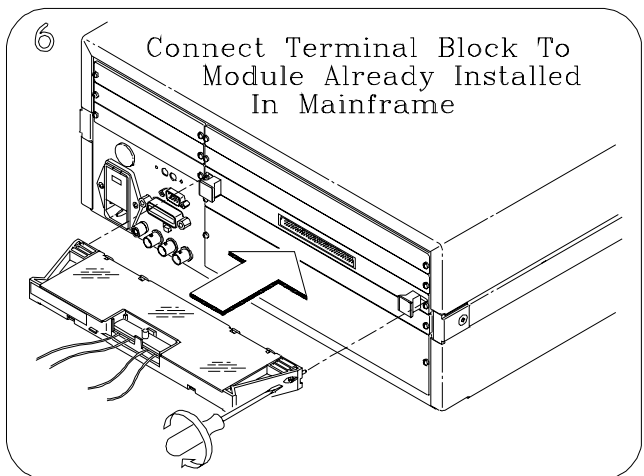
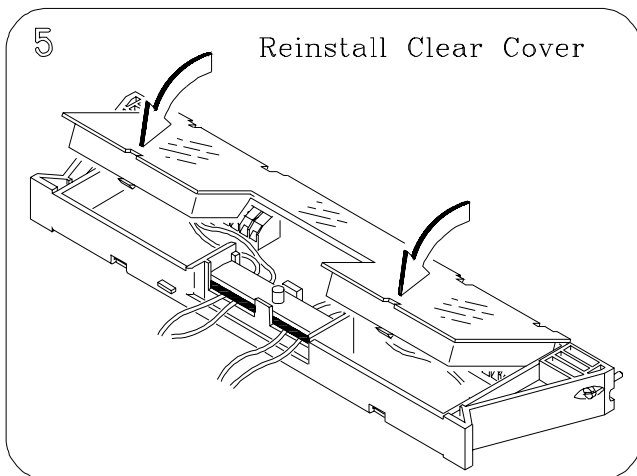
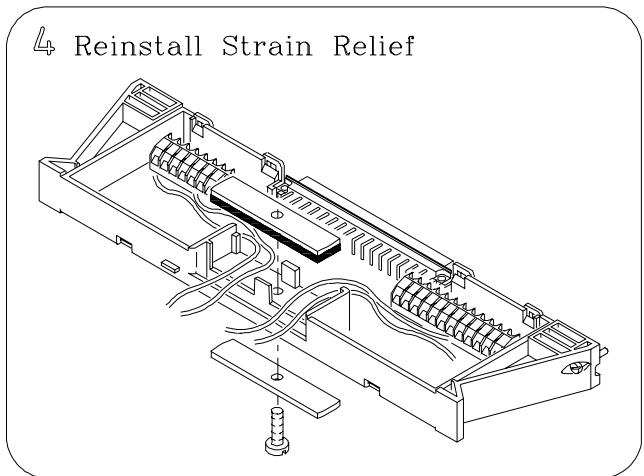
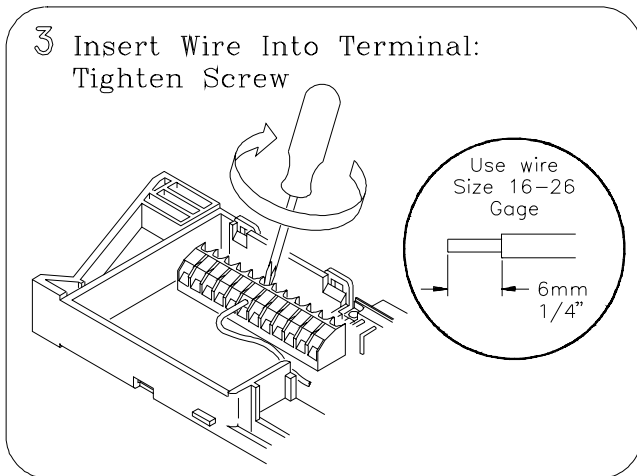
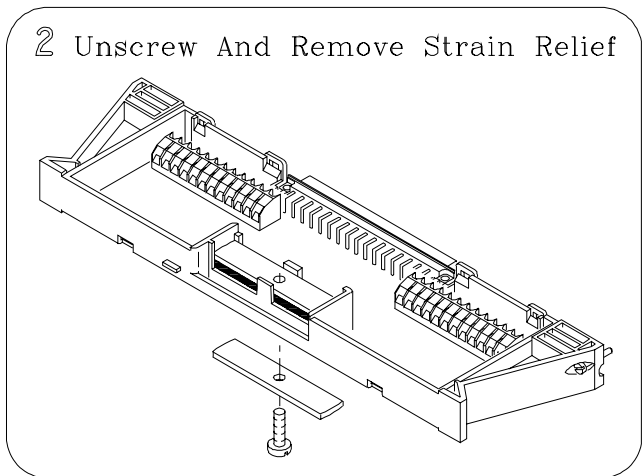
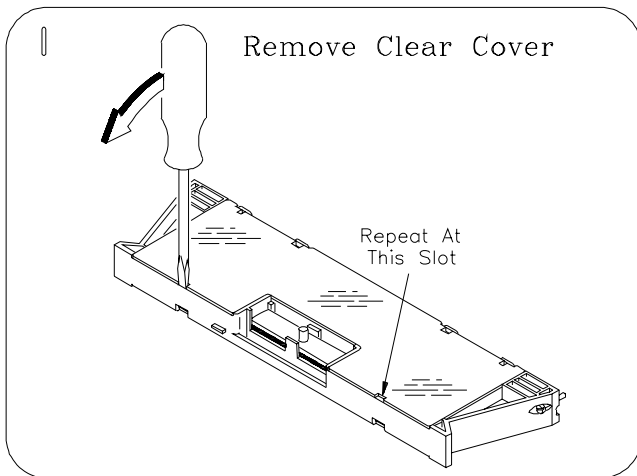

Figure 2-2. Wiring the Relay Matrix Terminal Block

Typical Matrix Configurations

The relay matrix can be configured as a 4 X 4 matrix or, by removing jumpers, can be configured as a dual 4 X 2 matrix. By connecting matrix cards, you can build larger matrixes.

4 X 4 Matrix Configuration

Figure 2-3 shows the relay matrix in a 4 row by 4 column matrix configuration. For this configuration, you can connect row inputs to either Bank A or Bank B rows, since the rows are connected by jumpers JM1-JM8. Note that both HIGH and LOW are switched for each relay. The circled number is the relay number and is also the channel number for programming.

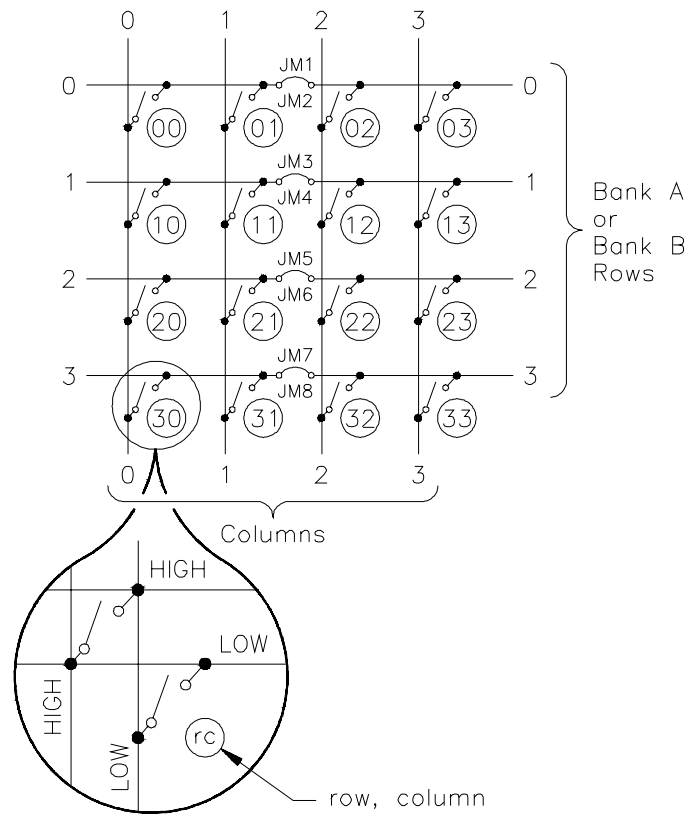

Figure 2-3. 4 X 4 Matrix

Dual 4 X 2 Matrix Configuration

By removing jumpers JM1-JM8 on the component card (see Figure 2-7 for location), you can configure the relay matrix into a dual 4 X 2 matrix. As shown in Figure 2-4, matrix #1 is formed by Bank A rows 0-3 and columns 0-1, while matrix #2 is formed by Bank B rows 0-3 and columns 2-3. Again, both HIGH and LOW are switched and the circled number is the relay/channel number.

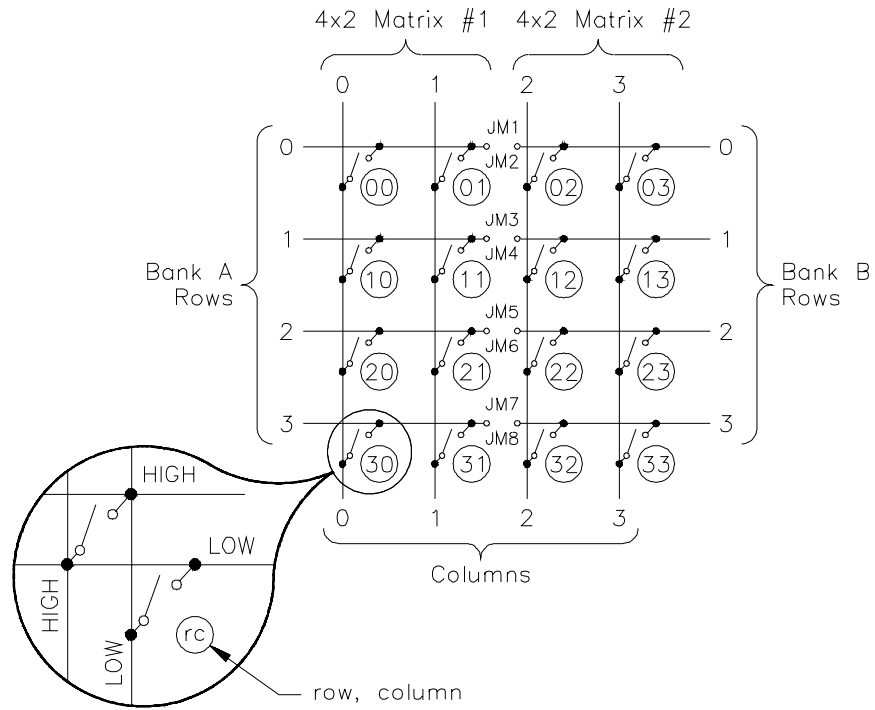

Figure 2-4. Dual 4 X 2 Matrix

Building Larger Matrixes

By making external (user) connections between relay matrix cards, you can build larger matrixes. For example, Figure 2-5 shows a 4 X 12 matrix using three relay matrix cards. To form this configuration, connect card #1 Bank B rows to card #2 Bank A rows, connect card #2 Bank B rows to card #3 Bank A rows, and connect user row inputs to card #3 Bank B rows.

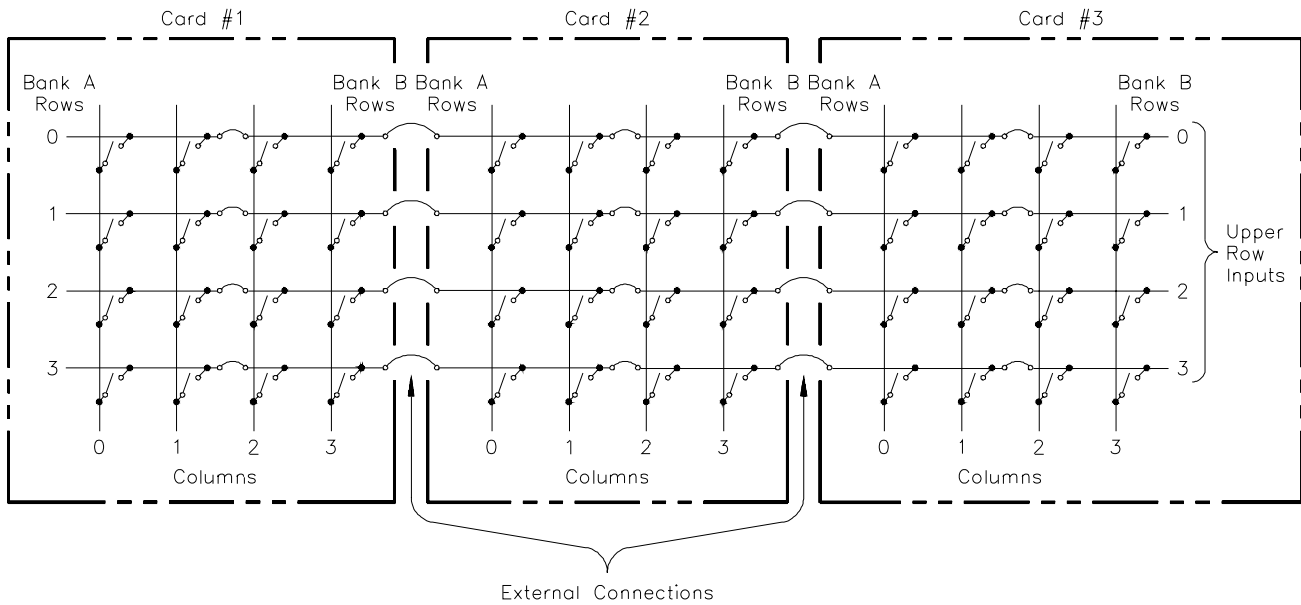

Figure 2-5. Typical 4 X 12 Matrix

High-Voltage Matrix Configuration

By connecting all columns together for a relay matrix in a dual 4 X 2 configuration, you can configure the matrix as an 8 X 1 high-voltage (up to 250 V) (2-wire) multiplexer. See Figure 2-6 for a typical representation.

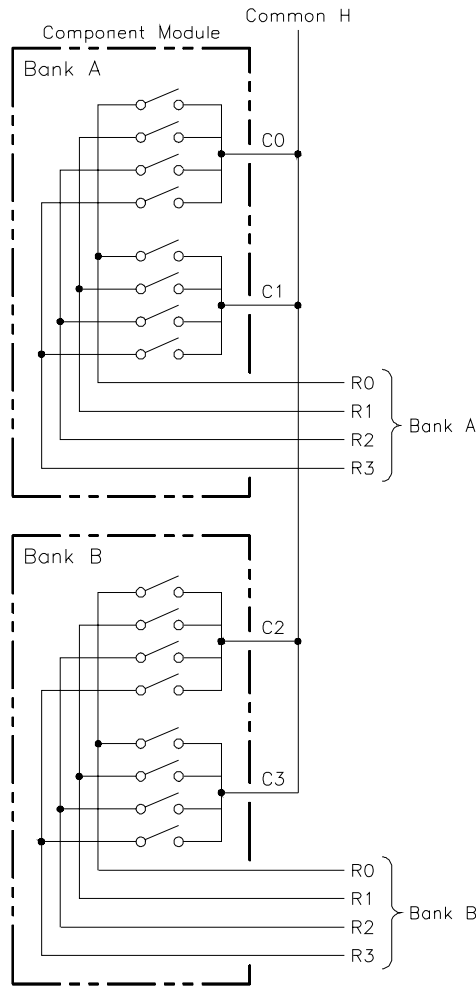

Figure 2-6. Typical 8 X 1 Multiplexer Arrangement

Changing Matrix Module Components

As required, you can change the following matrix components:

- Remove the channel jumpers (JM1-JM8).
- Change the Logical Address switch setting.
- Change the interrupt priority jumper positions.
- Replace fuses on the matrix component card.

See Figure 2-7 for component locations.

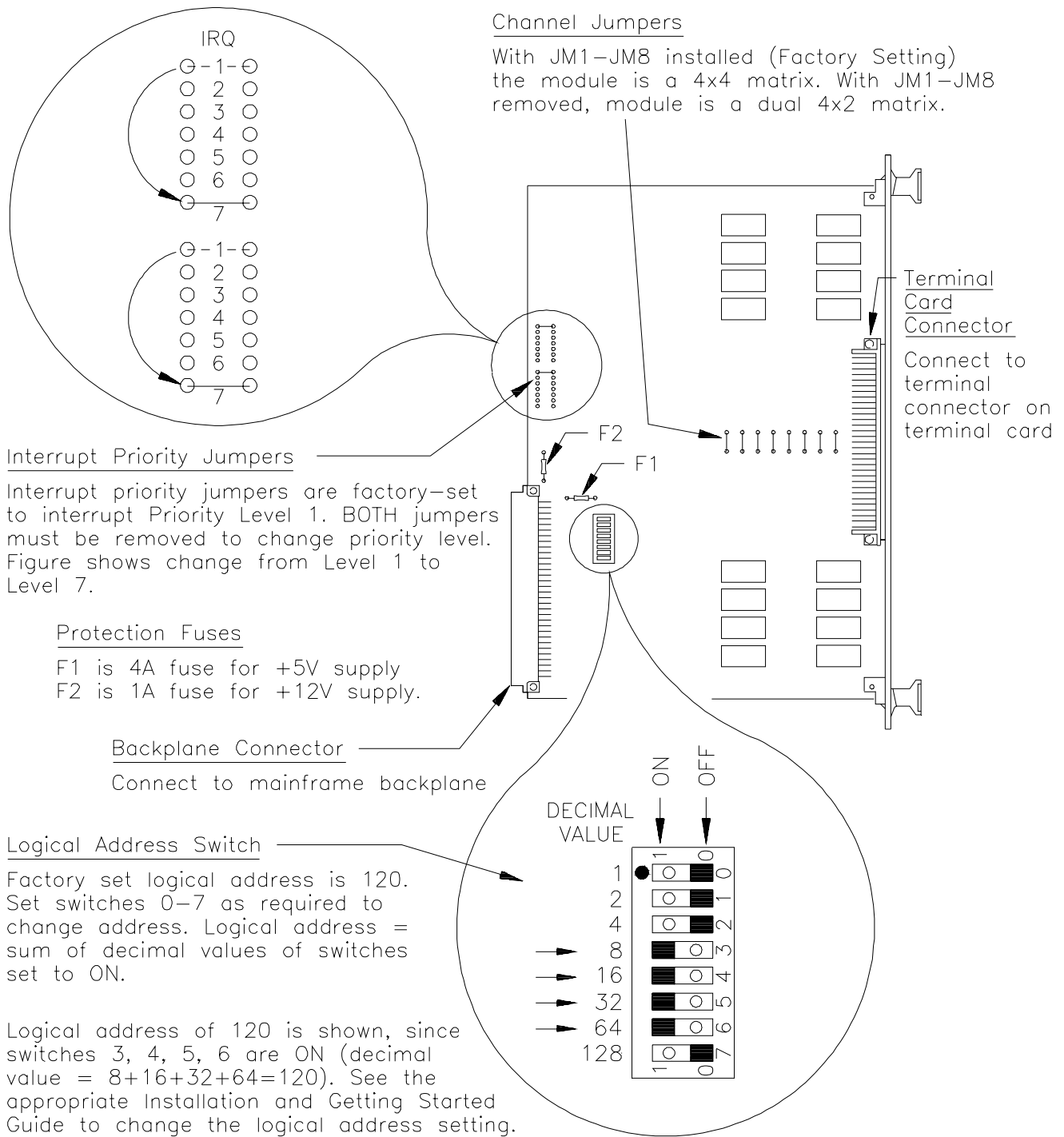

Figure 2-7. Relay Matrix Component Locations

Connecting User Inputs

The relay matrix module typically consists of a relay component module and a terminal block. Usually, you will make connections to the terminal block. If you desire to connect direct to the relay component module and not use the terminal block, Figure 2-8 shows the pin-out for the front panel connector.

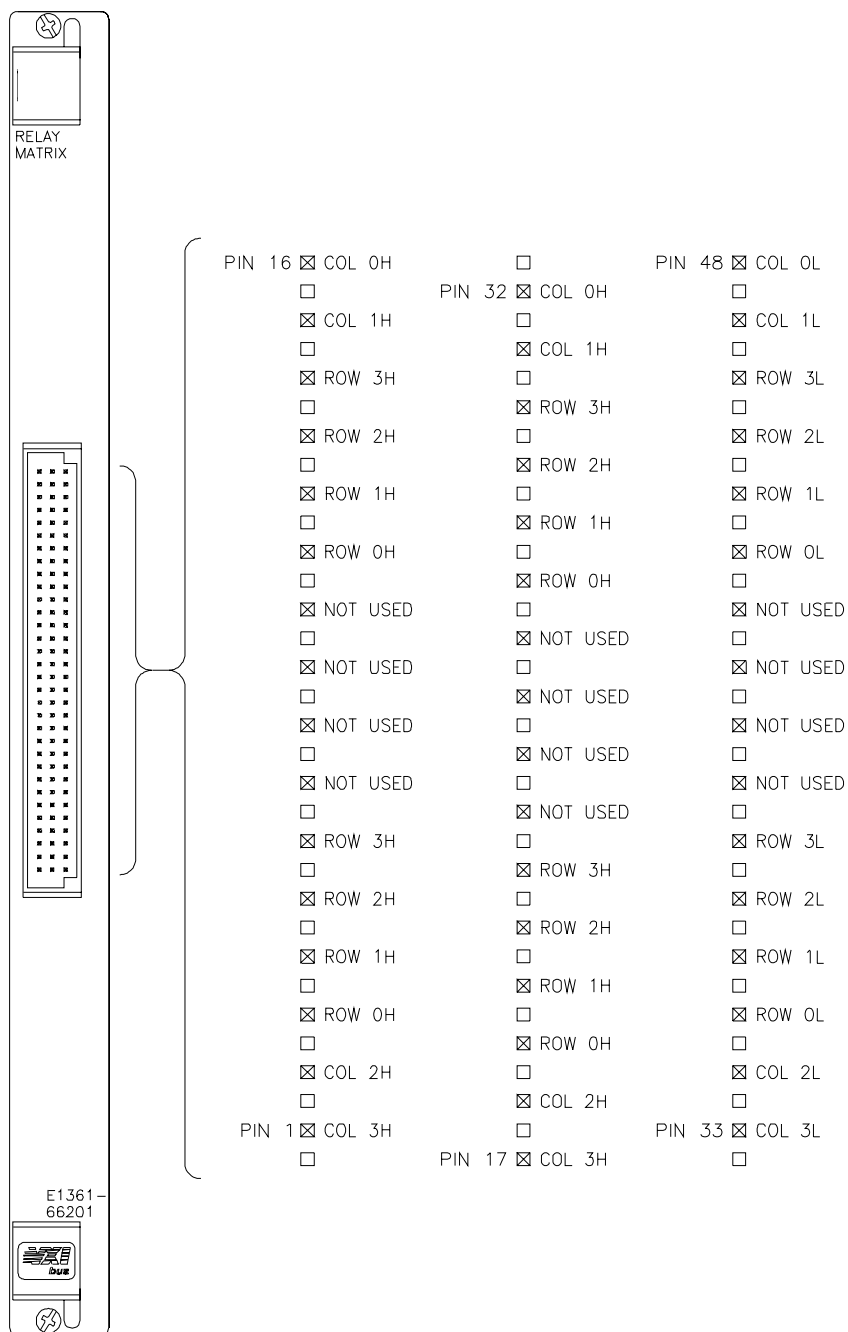

Figure 2-8. 4 X 4 Relay Matrix Front Panel

Chapter 3

Using the Agilent E1361A Relay Matrix

Using This Chapter

This chapter provides examples to use the relay matrix for switching channels. See Chapter 5, Relay Matrix Command Reference, for command information. Chapter contents are:

- Relay Matrix Commands Page 25
- Switching Channels Page 25

Relay Matrix Commands

Table 3-1. Relay Matrix Commands in Chapter 3

Command	Description
[ROUT:]CLOS<channel_list>	Close the channels in the <i>channel list</i> .
[ROUT:]CLOS?<channel_list>	Query the state of the channels in the <i>channel list</i> .
[ROUT:]OPEN <channel_list>	Open the channels in the <i>channel list</i> .

Switching Channels

- As factory-configured, the relay matrix module is a 4 X 4 matrix. By removing factory-installed jumpers JM1-JM8, the matrix is configured for dual 4 X 2 matrix operation.
- Use CLOS *channel_list* to close crosspoint relay(s) or use OPEN *channel_list* to open crosspoint relay(s). *channel_list* has the form (@nnrc) where nn = matrix card number (00-99), r = matrix row number (0-3), and c = matrix column number (0-3). The crosspoint relay number is also the channel number.
- SCAN *channel_list* can be used to scan (close) a specified set of channels. You can scan any combination of channels for a single-module or multiple-module switchbox. See Chapter 4, “Understanding the Relay Matrix” for scanning information.

Example: 4 X 4 Matrix Switching

This example closes channel 30 (relay 30) of a relay matrix in 4 X 4 configuration to connect the user input to row 3 with the user input to column 0. See Figure 3-1 for typical user connections. To close channel 30, execute:

CLOS (@130)

Close relay 30 (1 is card number)

To open channel 30 (relay 30), use OPEN (@130).

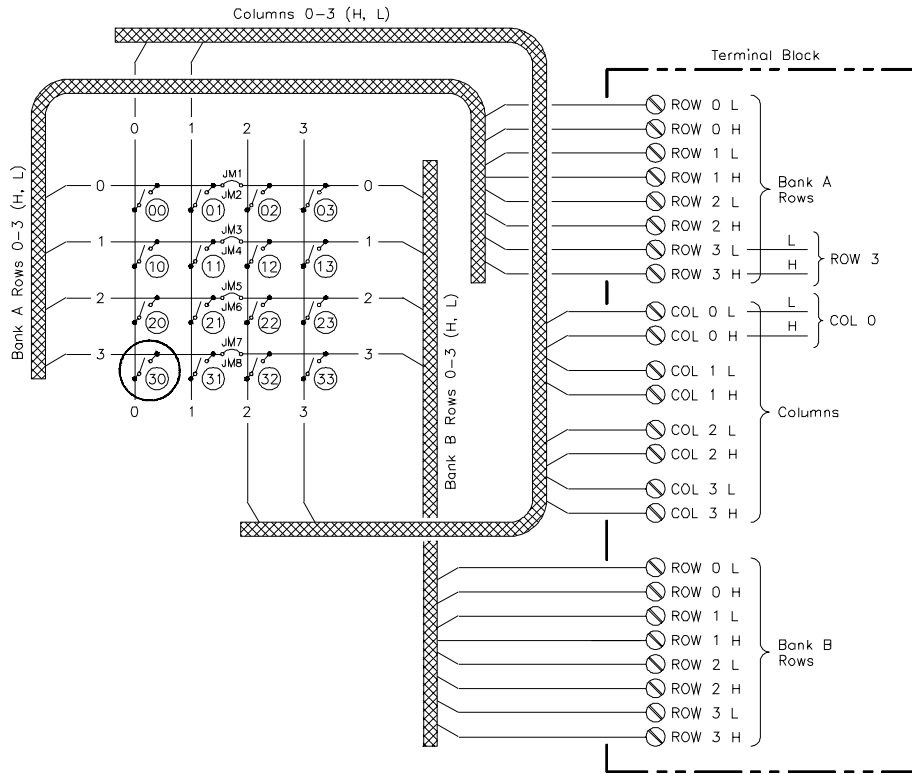

Figure 3-1. Example: 4 X 4 Matrix Switching

Example: Dual 4 X 2 Matrix Switching

This example closes relays 00 and 02 (channels 00 and 02) for a relay matrix in dual 4 X 2 configuration. Closing relay 00 connects the user input to Bank A Row 0 with the user input to Column 0. Closing relay 02 connects the user input to Bank B Row 0 with the user input to Column 2.

See Figure 3-2 for typical user connections (note that JM1-JM8 must be removed for dual 4 X 2 matrix configuration). To close channels 00 and 02 (relays 00 and 02), execute:

CLOS (@100,102)

Close channel 00 and 02 relays. 1 is the card number and 00 and 02 are the channel numbers.

To open channels 00 and 02, use OPEN (@100,102).

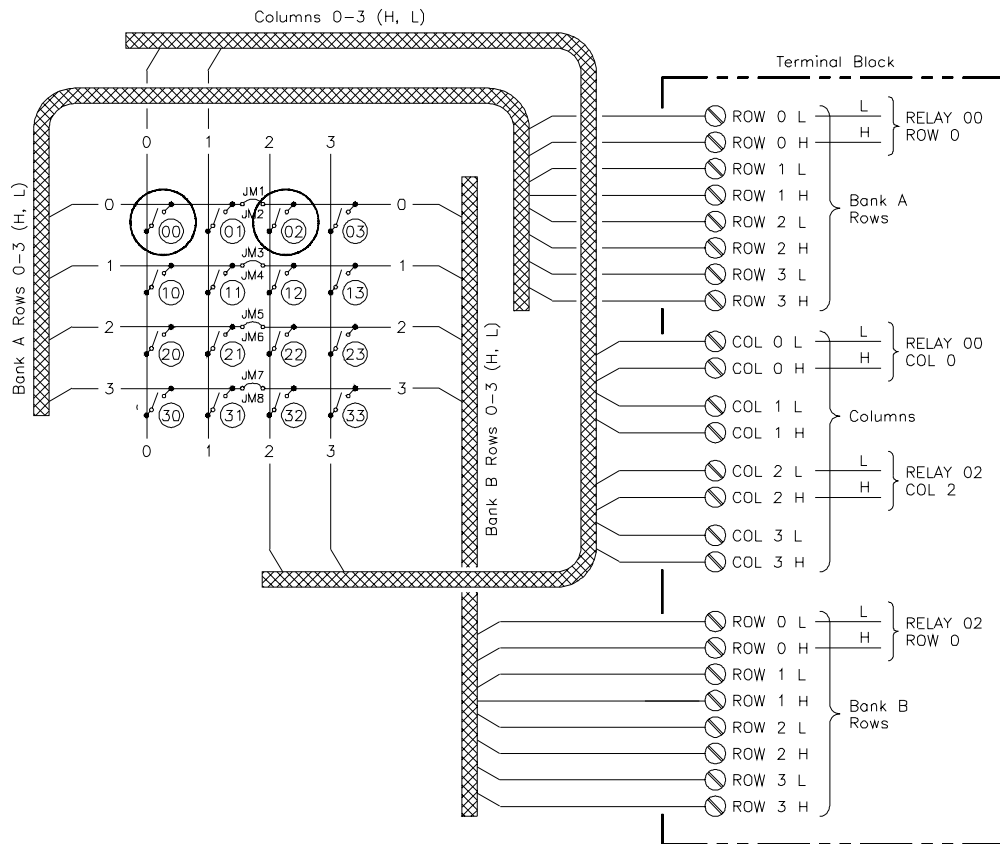

Figure 3-2. Example: Dual 4 X 2 Matrix Switching

Switching Channels Comments

Query Channel States. Use ROUTe:CLOS? *<channel_list>* or ROUTe:OPEN? *<channel_list>* to query channel states (open/closed). For each channel in the *<channel_list>*, ROUTe:CLOS? returns a 1 for each closed channel and a 0 for each open channel. ROUTe:OPEN? returns a 1 for each open channel and a 0 for each closed channel. (These are software queries which do not account for relay hardware failures.)

Channel Closure Order. ROUTe:CLOSe *<channel_list>* can be used to close multiple channels, but the sequence in which the channels are closed with a single command is not guaranteed.

Understanding the Agilent E1361A Matrix

Using This Chapter

This chapter explains techniques to scan relay matrix channels and shows how to use the Scan Complete bit. It also explains the response of the switchbox instrument to special 488.2 commands and the SCPI `SYSTEM:ERRor?` query. The chapter contents are:

- Scanning Channels Commands Page 29
- Using Scanning Trigger Sources Page 29
- Scanning with External Instruments Page 29
- Using the Scan Complete Bit. Page 34
- Special 488.2 Commands. Page 35
- SCPI Error Responses Page 35

Scanning Channels Commands

Scanning relay matrix channels consists of closing a set of channels one at a time. Single scan, multiple (2 to 32767) scans, or continuous scanning modes are available. See Figure 4-1 for scanning commands.

Using Scanning Trigger Sources

The `TRIG:SOUR` command specifies the source to advance the scan. You can use the `TRIG` command to advance the scan when `TRIG:SOUR BUS` or `TRIG:SOUR HOLD` is set. The `OUTPut` command can be used to enable the Agilent E1300B/E1301B Trig Out port. Figure 4-2 shows scanning trigger sources.

Scanning with External Instruments

Scanning relay matrix channels has the same effect as executing multiple `CLOSE` commands. Thus, scanning is useful when the outputs from a number of devices under test (DUT) are to be measured with an instrument. Two examples using the BASIC programming language are on pages 32 and 33.

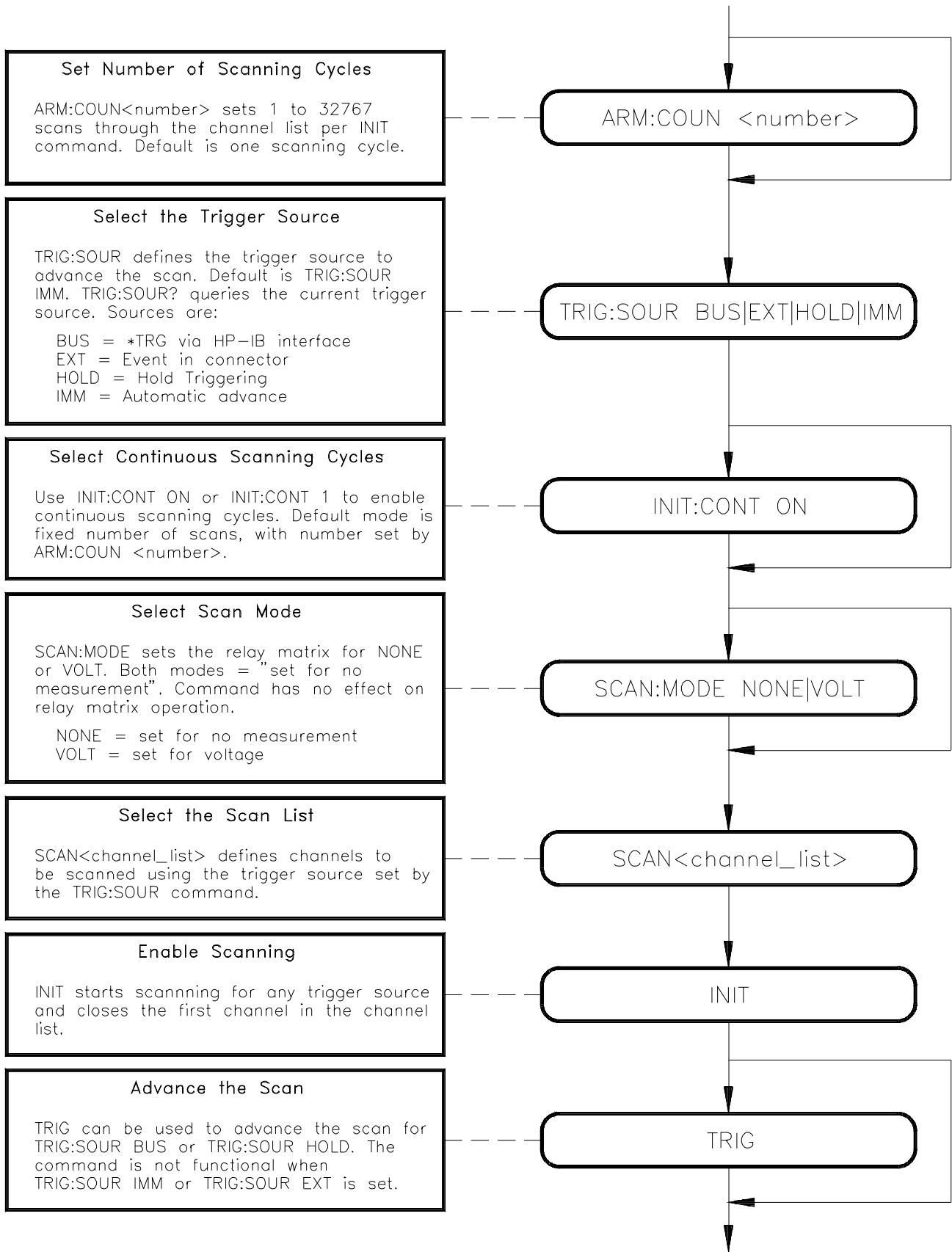

Figure 4-1. Scanning Channels Commands

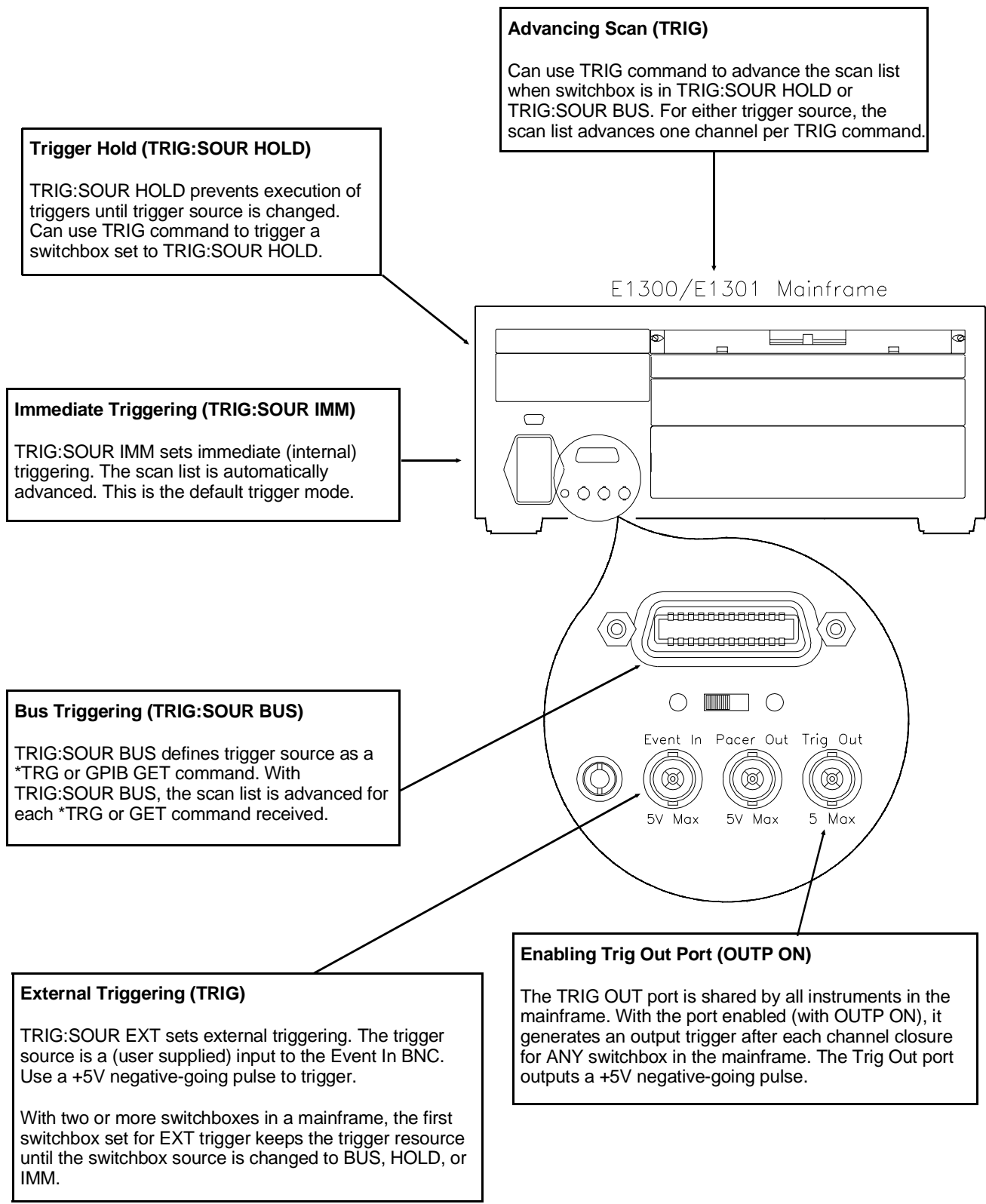

Figure 4-2. Scanning Trigger Sources

Example: Scanning with External Device

This example uses the Agilent E1300B/E1301B Mainframe Trig Out port to synchronize relay matrix channel closures to an external measurement device. See the following figure for typical user connections. For measurement synchronization, the Agilent E1300B/E1301B Trig Out BNC port is connected to the instrument External Trigger In port.

For this example, the Agilent E1300B/E1301B and the instrument are connected via GPIB with Agilent E1300B/E1301B address of 709 and instrument address of 722. The relay matrix logical address is 120 (secondary address = $120/8 = 15$). The measurements are transferred directly to the computer. (Appropriate instrument commands must be added to line 10 and you may need to add a WAIT statement at line 65 for slow measurements.)

The sequence of operation is:

1. INIT (line 50) closes channel 100.
2. Closure causes trigger output from the Trig Out port.
3. Trigger to Ext Trig In initiates channel 100 measurement.
4. Result is sent to the computer (lines 60-80).
5. TRIGGER (line 90) advances the scan to channel 101.
6. Steps 2-5 are repeated for channels 101-102.

```

10 OUTPUT 722;"TRIG EXT;..."      ! Configure instrument
20 OUTPUT 70915;"OUTP ON"          ! Enable Trig Out port
30 OUTPUT 70915;"TRIG:SOUR BUS"    ! GPIB bus triggering
40 OUTPUT 70915;"SCAN (@100:102)" ! Scan channels 00-02
50 OUTPUT 70915;"INIT"             ! Enable scan
60 FOR I=1 TO 3                    ! Start count loop
70 ENTER 722;A                     ! Enter reading
80 PRINT A                          ! Display reading
90 TRIGGER 70915                   ! Advance scan
100 NEXT I                          ! Increment count
110 END

```

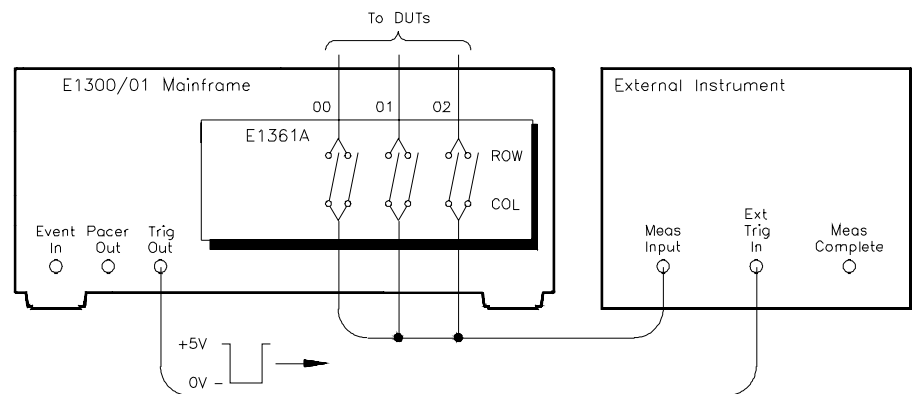

Example: Scanning Using Trig Out and Event In Ports

This example uses the Agilent E1300B/E1301B Mainframe Trig Out and Event In ports to synchronize relay matrix channel closures with an external measurement device. See the following figure for typical user connections. For this example, the mainframe and instrument are connected via GPIB with mainframe address of 709 and instrument address of 722. The relay matrix logical address is 120 (secondary address = $120/8 = 15$).

With this example, since synchronization with the computer cannot be ensured, the external instrument must have internal memory capacity to store the readings. Also, you must add the appropriate instrument commands to line 10.

The sequence of operation is:

1. INIT (line 50) closes channel 100.
2. Closure causes trigger to be output from Trig Out port.
3. Trigger to Ext Trig In starts channel 100 measurement.
4. Channel 100 measurement result is stored in instrument.
5. Trigger is then output from Measurement Complete port.
6. Trigger to Event In port advances scan to channel 101.
7. Steps 2-6 are repeated for channels 101-102.

```

10 OUTPUT 722;"TRIG EXT;..."      ! Configure instrument
20 OUTPUT 70915;"OUTP ON"          ! Enable Trig Out port
30 OUTPUT 70915;"TRIG:SOUR EXT"    ! Event In triggering
40 OUTPUT 70915;"SCAN (@100:102)" ! Scan channels 00-02
50 OUTPUT 70915;"INIT"             ! Enable scan
60 END

```

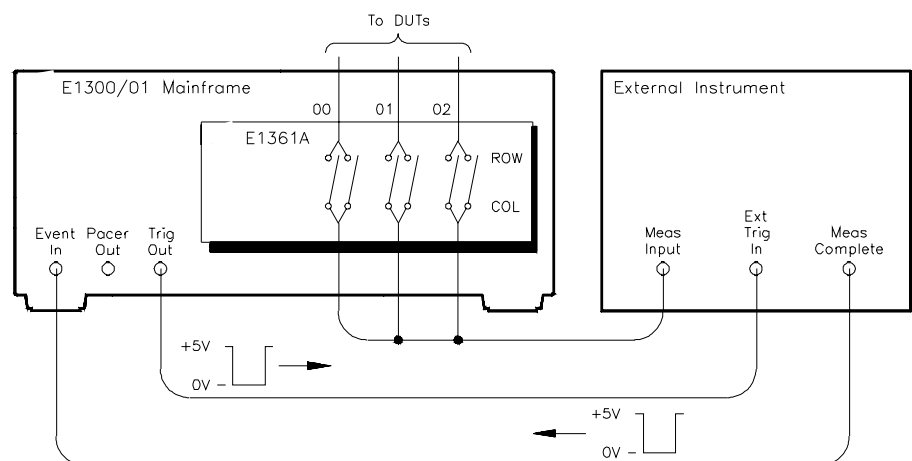

Using the Scan Complete Bit

You can use the Scan Complete bit (bit 8) in the Operation Status Register of a switchbox to determine when a scanning cycle completes (no other bits in the register apply to the switchbox). Bit 8 has a decimal value of 256 and you can read it directly with the STAT:OPER? command. See the STATus:OPERation[:EVENT]? command in Chapter 5 for an example.

When enabled by the STAT:OPER:ENAB 256 command, the Scan Complete bit will be reported as bit 7 of the Status Register. Use the GPIB Serial Poll or the IEEE 488.2 Common Command *STB? to read the Status Register. When bit 7 of the Status Register is enabled by the *SRE 128 Common Command to assert an GPIB Service Request (SRQ), you can interrupt the computer when the Scan Complete bit is set, after a scanning cycle completes. This allows the computer to do other operations while the scanning cycle is in progress.

The following example monitors bit 7 in the Status Register to determine when the scanning cycle completes. The computer used in this example is an HP 9000 Series 200/300 used with BASIC as the programming language. The computer interfaces with an Agilent E1300B/E1301B mainframe over GPIB. The GPIB select code is 7, the GPIB primary address is 09, and the GPIB secondary address is 15.

Example: Scan Complete Interrupt

```
10 OUTPUT 70915;"*CLS"           ! Clear all switchbox status
                                ! structure.
20 OUTPUT 70915;"STAT:OPER:ENAB 256"! Enable Scan Complete bit to
                                ! set bit 7 in Status register.
30 OUTPUT 70915;"*SRE 128"       ! Enable bit 7 of Status
                                ! Register to assert SRQ.
40 OUTPUT 7915;"TRIG:SOUR EXT"   ! External trigger mode
50 OUTPUT 70915;"SCAN (@100:105)" ! Select channels to be scanned
60 OUTPUT 70915;"INIT"          ! Start scanning cycle
70 WHILE NOT BIT(SPOLL(70915),7) ! Wait for scan complete
80 PRINT "DO OTHER OPERATION HERE"! Enter program lines for
                                ! computer to do other operations
90 END WHILE
100 PRINT "INTERRUPT GENERATED" ! Program goes to this line after
                                ! interrupt is generated by a
                                ! completed scanning cycle
110 END
```

Special 488.2 Commands

This section contains information about the response of the switchbox instrument to three IEEE 488.2 common commands.

Storing States

The `*SAV <numeric_state>` command saves the current instrument state. The state number (0-9) is specified by the `numeric_state` parameter. The settings saved by this command are:

- ARM:COUNT
- TRIGger:SOURce
- OUTPut:STATE
- INITiate:CONTInuous
- SCAN (the scan list is set to invalid; therefore, the command does not save a scan list.)
- SCAN:MODE
- SCAN:PORT

Recalling States

The `*RCL <numeric_state>` command recalls the state when the last `*SAV` was executed for the specified `numeric_state` parameter (0-9). If no `*SAV` was executed for the `numeric_state`, `*RST` default settings are used. Refer to the `*SAV` settings list for the settings recalled by `*RCL`.

Response to *RST

The `*RST` command opens all channels, invalidates the current channel list for scanning, and sets the following:

- ARM:COUNT 1
- TRIGger:SOURce IMM
- INIT:CONTInuous OFF
- OUTPut OFF
- SCAN:MODE NONE
- SCAN:PORT NONE

SCPI Error Responses

The `SYSTEM:ERROR?` query requests a value from the instrument's error register. This register contains an integer in the range [-32768 to 32767]. The response takes the following form:

`<err_number>,<err_message>`

The `<err_number>` is the value of the instrument's error register. The `<err_message>` is a short description of the error, followed by further information about the error.

If no error occurs, the switchbox responds with 0,"No error". If there has been more than one error, the instrument will respond with the first one in its error queue. Subsequent queries continue to read the error queue until it is empty. The maximum `<err_message>` string length is 255 characters.

Chapter 5

Agilent E1361A Relay Matrix Command Reference

Using This Chapter

This chapter summarizes SCPI (Standard Commands for Programmable Instruments) commands and summarizes IEEE 488.2 Common (*) Commands in this manual.

See the *Agilent 75000 Series B B-Size VXIbus Mainframe (Agilent E1300B/E1301B) User's Manual* or the *Agilent 75000 Series C Agilent E1405A User's Manual* for additional information on SCPI and common commands. Chapter contents are:

- Command Types Page 37
- SCPI Command Format Page 38
- SCPI Command Reference Page 40
- IEEE 488.2 Common Commands Page 59
- Command Quick Reference Page 60

Command Types

Commands are separated into two types: IEEE 488.2 Common Commands and SCPI Commands.

Common Command Format

The IEEE 488.2 standard defines the common commands that perform functions like reset, self-test, status byte query, etc. Common commands are four or five characters in length, always begin with the asterisk character (*), and may include one or more parameters. The command keyword is separated from the first parameter by a space character. Some examples of common commands are shown below:

*RST *ESR 32 *STB?

SCPI Command Format

SCPI commands perform functions like closing switches, querying instrument states, and retrieving data. A subsystem command structure is a hierarchical structure that usually consists of a top level (or root) command, one or more lower level commands, and their parameters. The following example shows part of a typical subsystem:

```
[ROUTe:]  
  CLOSe <channel_list>  
  SCAN <channel_list>  
    :MODE?
```

ROUTe: is the root command, CLOSe and SCAN are second level commands, and :MODE? is a third level command.

Command Separator

A colon (:) always separates one command from the next lower level command as shown below:

```
ROUTe:SCAN:MODE?
```

Colons separate the root command from the second level command (ROUTe:SCAN) and the second level from the third level (SCAN:MODE?).

Abbreviated Commands

The command syntax shows most commands as a mixture of upper and lower case letters. The upper case letters indicate the abbreviated spelling for the command. For shorter program lines, send the abbreviated form. For better program readability, you may send the entire command. The instrument will accept either the abbreviated form or the entire command. For example, if the command syntax shows MEASure, then both MEAS and MEASURE are acceptable forms. Other forms of MEASure, such as MEASU or MEASUR will generate an error. Use upper or lower case letters. Therefore, MEASURE, measure, and MeAsUrE are acceptable.

Implied Commands

Implied commands are those which appear in square brackets ([]) in the command syntax. (Note that the brackets are not part of the command and are not sent to the instrument.) Suppose you send a second level command but do not send the preceding implied command. In this case, the instrument assumes you intend to use the implied command and it responds as if you had sent it. Examine the SOURce subsystem shown below:

```
[SOURce:]  
  PULSe  
    :COUNt <count>  
    :COUNt? [<MIN | MAX>]  
    :PERiod <period>  
    :PERiod? [<MIN | MAX>]
```

The root command **SOURce:** is an implied command. To set the instrument's pulse count to 25, you can send either of the following command statements:

SOUR:PULS:COUN 25 *or* PULS:COUN 25

Parameters **Parameter Types.** The following table contains explanations and examples of the parameter types you might see later in this chapter.

Table 5-1. SCPI Parameter Types

Parameter Type	Explanations and Examples
Numeric	Accepts all commonly used decimal representations of numbers including optional signs, decimal points, and scientific notation. 123, 123E2, -123, -1.23E2, .123, 1.23E-2, 1.23000E-01. Special cases include MIN, MAX, and INF.
Boolean	Represents a single binary condition that is either true or false. ON, OFF, 1, 0.
Discrete	Selects from a finite set of values. These parameters use mnemonics to represent each valid setting. An example is TRIGger:SOURce <source> where <source> can be BUS, EXT, HOLD, or IMM.

Optional Parameters. Parameters shown within square brackets ([]) are optional parameters. (Note that the brackets are not part of the command and are not sent to the instrument.) If you do not specify a value for an optional parameter, the instrument chooses a default value.

For example, consider the ARM:COUNT? [MIN | MAX] command. If you send the command without specifying a parameter, the present ARM:COUNT value is returned. If you send the MIN parameter, the command returns the minimum count available. If you send the MAX parameter, the command returns the maximum count available. Be sure to place a space between the command and the parameter.

Linking Commands

Linking IEEE 488.2 Common Commands with SCPI Commands:

Use a semicolon between the commands. For example:

```
*RST;OUTP ON or TRIG:SOUR HOLD;*RST
```

Linking Multiple SCPI Commands:

Use both a semicolon (;) and a colon (:) between the commands.

For example:

```
ARM:COUN 1::TRIG:SOUR EXT
```

SCPI Command Reference

This section describes the Standard Commands for Programmable Instruments (SCPI) commands for the relay matrix. Commands are listed alphabetically by subsystem and also within each subsystem.

ABORt

The ABORt command subsystem stops a scan in progress when the scan is enabled via the interface and the trigger source is TRIGger:SOURce BUS or TRIGger:SOURce HOLD.

Subsystem Syntax

ABORt

Comments

- **ABORt Actions:** ABORt invalidates the current channel list and sets ARM:COUNT 1 (one scanning cycle per INITiate command), sets INITiate:CONTinuous OFF (no continuous scanning cycles), and sets TRIGger:SOURce IMMEDIATE (immediate internal triggering).
- **Stopping Scan Enabled Via Interface:** When a scan is enabled via an interface, an interface CLEAR command or the Agilent E1301B front panel "Reset Instr" or "Clear Instr" keys can be used to stop the scan. When the scan is enabled via the interface and TRIG:SOUR BUS or HOLD is set you can use ABORt or the Agilent E1301B front panel "Reset Instr" or "Clear Instr" keys to stop the scan.
- **Stopping Scan Enabled From Front Panel:** When a scan is enabled from the Agilent E1301B front panel, you can use *RST entered via the interface or the front panel "Reset Instr" or "Clear Instr" keys to stop the scan.
- **Related Commands:** ARM, INITiate:CONTinuous, [ROUTE:]SCAN, TRIGger

Example Stopping a Scan with ABORt

This example stops a (continuous) scan in progress.

TRIG:SOUR BUS	<i>*TRG command is trigger source</i>
INIT:CONT ON	<i>Set continuous scanning</i>
SCAN (@100:103)	<i>Scan channels 00-03</i>
INIT	<i>Start scan, close channel 00</i>
.	
.	
ABOR	<i>Abort scan in progress</i>

ARM

The ARM subsystem selects the number of scanning cycles (1 to 32767) for each INITiate command.

Subsystem Syntax

ARM
:COUNT <number> MIN | MAX
:COUNT? [MIN | MAX]

:COUNT **ARM:COUNT <number> MIN | MAX** allows scanning cycles to occur a multiple of times (1 to 32767) with one INITiate command when INITiate:CONTinuous OFF | 0 is set. MIN sets 1 cycle and MAX sets 32767 cycles.

Parameters

Parameter Name	Parameter Type	Range of Values
<i>number</i>	numeric	1-32767 MIN MAX

Comments

- **Number of Scans:** Use only values between 1 and 32767 for the number of scanning cycles.
- **Related Commands:** ABORt, INITiate:IMMediate
- ***RST Condition:** ARM:COUNT 1

Example Setting Ten Scanning Cycles

This example sets a relay matrix for 10 scans of channels 00 through 03. When the scan sequence completes, channels 00 through 03 (relays 00 through 03) are closed.

ARM COUN 10	<i>Set 10 scans per INIT command</i>
SCAN (@100:103)	<i>Scan channels 00-03</i>
INIT	<i>Start scan, close channel 00</i>

DISPlay

The DISPlay subsystem monitors the channel state of a selected module (or card) in a switchbox. This subsystem operates only with mainframes which have a display, such as the Agilent 75000 Series B mainframe (Agilent Model Number E1301B).

Subsystem Syntax

```
DISPlay  
:MONitor  
:CARD <number | AUTO>  
[:STATe] <mode>
```

MONitor:CARD

DISPlay:MONitor:CARD <number / AUTO> selects the module in a switchbox to be monitored.

Parameters

Parameter Name	Parameter Type	Range of Values
<i>number</i> AUTO	numeric	1-99

Comments

- **Selecting a Specific Module to be Monitored:** Use the DISPlay:MONitor:CARD command to send the card number for the switchbox to be monitored.
- **Selecting the Present Module to be Monitored:** Use the DISPlay:MONitor:CARD AUTO command to select the last module addressed by a switching command (e.g., [ROUTE:]CLOSe).
- ***RST Condition:** DISPlay:MONitor:CARD AUTO

Example

Select Module #2 in a Switchbox for Monitoring

```
DISP:MON:CARD 2
```

Selects module #2 in a switchbox

MONitor[:STATe] DISPlay:MONitor[:STATe] *<mode>* turns the monitor mode ON or OFF.

Parameters

Parameter Name	Parameter Type	Range of Values
<i>mode</i>	boolean	ON OFF 1 0

Comments

- **Monitoring Switchbox Channels:** DISPlay:MONitor[:STATe] ON or DISPlay:MONitor[:STATe] 1 turns the monitor mode ON to show the channel state of the selected module. DISPlay:MONitor[:STATe] OFF or DISPlay:MONitor[:STATe] 0 turns the monitor mode OFF.

- **Selecting the Module to be Monitored:** Use the DISPlay:MONitor:CARD *<number>*AUTO command to select the module.

- **Monitor Mode on an Agilent E1301B Mainframe Display:** A typical display for the Agilent E1361A 4 X 4 Relay Matrix module follows, where all channels (all relays) are closed. R0 = row 0, etc.

R0:0,1,2,3 R1:0,1,2,3 R2:0,1,2,3 R3:0,1,2,3

- ***RST Condition:** DISPlay:MONitor[:STATe] OFF | 0

Example Enabling the Monitor Mode

DISP:MON:CARD 2

Selects module#2 in a switchbox

DISP:MON 1

Turns monitor mode ON

INITiate

The INITiate command subsystem selects continuous scanning cycles and starts the scanning cycle.

Subsystem Syntax

```
INITiate
:CONTinuous <mode>
:CONTinuous?
[:IMMediate]
```

:CONTinuous

INITiate:CONTinuous <mode> enables or disables continuous scanning cycles for the switchbox.

Parameters

Parameter Name	Parameter Type	Range of Values
<i>mode</i>	boolean	ON OFF 1 0

Comments

- **Continuous Scanning Operation:** Continuous scanning is enabled with the INITiate:CONTinuous ON or INITiate:CONTinuous 1 command. Sending the INITiate:IMMediate command closes the first channel in the channel list. Each trigger from a trigger source selected by the TRIGger:SOURce command advances the scan through the channel list. A trigger at the end of the channel list closes the first channel in the channel list and the scan cycle repeats.
- **Non-Continuous Scanning Operation:** Non-continuous scanning is enabled with the INITiate:CONTinuous OFF or INITiate:CONTinuous 0 command. Sending the INITiate:IMMediate command closes the first channel in the channel list. Each trigger from a trigger source selected by the TRIGger:SOURce command advances the scan through the channel list. At the end of the scanning cycle, the last channel in the channel list is closed.
- **Stopping Continuous Scan:** See the ABORt command.
- **Related Commands:** ABORt, ARM:COUNT, TRIGger, TRIGger:SOURce
- ***RST Condition:** INITiate:CONTinuous OFF

Example Enabling Continuous Scanning

This example enables continuous scanning of channels 00 through 03 of a single-module switchbox. Since TRIGger:SOURce IMMediate (default) is set, use an interface clear command (such as CLEAR) to stop the scan.

```
INIT:CONT ON           Enable continuous scanning
SCAN (@100:103)       Defines channel list
INIT                   Start scan cycle, close channel 00
```

:CONTInuous? **INITiate:CONTInuous?** queries the scanning state. With continuous scanning enabled, the command returns 1. With continuous scanning disabled, the command returns 0.

Example Query Continuous Scanning State

This example enables continuous scanning of a switchbox and queries the state. Since continuous scanning is enabled, INIT:CONT? returns 1.

```
INIT:CONT ON Enable continuous scanning
INIT:CONT? Query continuous scanning state
```

[:IMMEDIATE] **INITiate[:IMMEDIATE]** starts the scanning process and closes the first channel in the channel list. Successive triggers from the source selected by the TRIGger:SOURce command advance the scan through the channel list.

Comments

- **Starting the Scanning Cycle:** The INITiate:IMMEDIATE command starts scanning by closing the first channel in the channel list. Each trigger received advances the scan to the next channel in the channel list. An invalid channel list definition causes an error (see [ROUTE:]SCAN).
- **Stopping Scanning Cycles:** See ABORT.

Example Enabling a Single Scan

This example enables a single scan of channels 00 through 03 of a single-module switchbox. The trigger source to advance the scan is immediate (internal) triggering set with (default) TRIGger:SOURce IMMEDIATE.

```
SCAN (@100:103 Scan channels 00-03
INIT Begin scan, close channel 00
(use immediate triggering).
```

[ROUTE:]

The [ROUTE:] command subsystem controls switching and scanning operations for relay matrix modules in a switchbox.

Subsystem Syntax

```
[ROUTE:]  
  CLOSe <channel_list>  
  CLOSe? <channel_list>  
  OPEN <channel_list>  
  OPEN? <channel_list>  
  SCAN <channel_list>  
      :MODE NONE | VOLT  
      :MODE?
```

CLOSe [ROUTE:]**CLOSe** <channel_list> closes the relay matrix channels specified by *channel_list*. *channel_list* has the form (@nnrc) where nn = matrix card number (01-99), r = matrix row number (0-3), and c = matrix column number (0-3).

Parameters

Parameter Name	Parameter Type	Range of Values
<i>channel_list</i>	numeric	nn00-nn03, nn10-nn13, nn20-nn23, nn30-nn33

Comments

- **Closing Channels:**
 - To close a single channel, use [ROUTE:]CLOSe (@nnrc);
 - for multiple channels use [ROUTE:]CLOSe (@nnrc,nnrc,...);
 - for sequential channels, use [ROUTE:]CLOSe (@nnrc:nnrc);
 - for groups of sequential channels, use [ROUTE:]CLOSe (@nnrc:nnrc,nnrc:nnrc);
 - or any combination.

Closure order for multiple channels with a single command is not guaranteed.

- **Related Commands:** [ROUTE:]OPEN, [ROUTE:]CLOSe?

- ***RST Condition:** All channels open

Example Closing Matrix Channels

This example closes channels 100 and 213 of a two-module switchbox (card numbers 01 and 02).

```
CLOS (@100,213)
```

Close channels 100 and 213. 100 closes channel 00 of card #1 and 213 closes channel 13 of card #2.

CLOSe? [ROUTE:]CLOSe? <channel_list> returns the current state of the channel(s) queried. *channel_list* has the form (@nnrc) (see [ROUTE:]CLOSe for definition). The command returns 1 if channel(s) are closed or returns 0 if channel(s) are open.

- Comments**
- **Query is Software Readback:** The [ROUTE:]CLOSe? command returns the current software state of the channel(s) specified. It does not account for relay hardware failures. A maximum of 127 channels at a time can be queried for a multi-module switchbox.

Example Query Channel Closure

This example closes channels 100 and 213 of a two-module switchbox and queries channel closure. Since the channels are programmed to be closed 1,1 is returned as a string.

```
CLOS (@100,213)           Close channels 100 and 213
CLOS? (@100,213)        Query channels 100 and 213 state
```

OPEN [ROUTE:]OPEN <channel_list> opens the relay matrix channels specified by *channel_list*. *channel_list* has the form (@nnrc) where nn = matrix card number (01-99), r = matrix row number (0-3), and c = matrix column number (0-3).

Parameters

Parameter Name	Parameter Type	Range of Values
<i>channel_list</i>	numeric	nn00-nn03, nn10-nn13, nn20-nn23, nn30-nn33

- Comments**
- **Opening Channels:**
 - To open a single channel, use [ROUTE:]OPEN (@nnrc);
 - for multiple channels use [ROUTE:]OPEN (@nnrc,nnrc,...);
 - for sequential channels, use [ROUTE:]OPEN (@nnrc:nnrc);
 - for groups of sequential channels, use [ROUTE:]OPEN (@nnrc:nnrc,nnrc:nnrc);
 - or any combination.

Opening order for multiple channels with a single command is not guaranteed.
 - **Related Commands:** [ROUTE:]CLOSe, [ROUTE:]OPEN?
 - ***RST Condition:** All channels open.

Example Opening Channels

This example opens channels 100 and 213 of a two-module switchbox (card numbers 01 and 02).

```
OPEN (@100,213)           Open channels 100 and 213. 100
                          opens channel 00 of #1 and 213
                          opens channel 13 of card #2.
```

OPEN? [ROUTE:]OPEN? <channel_list> returns the current state of the channel(s) queried. *channel_list* has the form (@nnrc) (see [ROUTE:]OPEN for definition). The command returns 1 if channel(s) are open or returns 0 if channel(s) are closed.

- Comments**
- **Query is Software Readback:** The ROUTE:OPEN? command returns the current software state of the channels specified. It does not account for relay hardware failures. A maximum of 127 channels at a time can be queried for a multi-module switchbox.

Example Query Channel Open State

This example opens channels 100 and 213 of a two-module switchbox and queries channel 213 state. Since channel 213 is programmed to be open, 1 is returned.

```
OPEN (@100,213)           Open channels 100 and 213
OPEN? (@213)             Query channel 213 state
```

SCAN [ROUTE:]SCAN <channel_list> defines the channels to be scanned. *channel_list* has the form (@nnrc) where nn = matrix card number (01-99), r = matrix row number (0- 3), and c = matrix column number (0-3).

Parameters

Parameter Name	Parameter Type	Range of Values
<i>channel_list</i>	numeric	nn00-nn03, nn10-nn13, nn20-nn23, nn30-nn33

- Comments**
- **Defining Scan List:** When [ROUTE:]SCAN is executed, the channel list is checked for valid card and channel numbers. An error is generated for an invalid channel list.
 - **Scanning Channels:**
 - You can scan single channels (@nnrc);
 - multiple channels (@nnrc,nnrc,...);
 - sequential channels (@nnrc:nnrc);
 - groups of sequential channels (@nnrc:nnrc,nnrc:nnrc);
 - or any combination.
 - **Scanning Operation:** When a valid channel list is defined, INITiate[:IMMEDIATE] begins the scan and closes the first channel in the channel list. Successive triggers from the source specified by TRIGger:SOURce advance the scan through the channel list.
 - **Stopping Scan:** See ABORT.
 - **Related Commands:** TRIGger, TRIGger:SOURce
 - ***RST Condition:** All channels open.

Example Scanning Using External Device

See Chapter 4, “Example: Scanning with External Device” or “Example: Scanning Using Trig Out and Event In Ports” for example scanning programs using external instruments.

SCAN:MODE [ROUTE:]SCAN:MODE NONE | VOLT can be used for the relay matrix. Both NONE and VOLT set the mode for "no measurements". This command has no effect on relay matrix operation.

SCAN:MODE? [ROUTE:]SCAN:MODE? can be used to query the scanning mode (NONE or VOLT) for the relay matrix.

STATus

The STATus subsystem reports the bit values of a Standard Operation Status Register. Enables the Status Register to set a bit after a bit is set to 1 by the Standard Operation Register.

Subsystem Syntax

```
STATus
:OPERation
:ENABLE <number>
[:EVENT]?
```

:OPERation:ENABLE

STATus:OPERation:ENABLE <number> enables the Operation Status Register to set a bit in the Status Register. Setting bit 8 in the Operation Status Register to 1 sets bit 7 in the Status Register to 1, when enabled.

Parameters

Parameter Name	Parameter Type	Range of Values
<i>number</i>	numeric	1-32767

Comments

- **Setting Bit 7 of the Status Register:** STATus:OPERation:ENABLE 256 sets bit 7 of the Status Register to 1 after bit 8 of the Operation Status Register is set to 1.
- **Related Commands:** [ROUTe:]SCAN

Example

Enabling Status Register Bit 7

```
STAT:OPER:ENAB 256
```

Enables bit 7 of Status Register

:OPERation[:EVENT]?

STATus:OPERation[:EVENT]? returns the bit value of the Operation Status Register (only bit 8 is used by the matrix modules).

Comments

- **Setting Bit 8 of the Operation Status Register:** Bit 8 (Scan Complete) is set to 1 after a scanning cycle completes. Bit 8 returns to 0 after sending the STATus:OPERation[:EVENT]? command.
- **Returned Data After Sending the STATus:OPERation[:EVENT]? command:** The command returns +256 if bit 8 of the Operation Status Register is set to 1 or it returns +0 if bit 8 of the Operation Status Register is set to 0.
- **Related Commands:** [ROUTe:]SCAN

Example

Reading the Operation Status Register After a Scanning Cycle

```
STAT:OPER?
```

Returns bit values of the Standard Operation Status Register. Returns +256 if bit 8 is set to 1 or returns +0 if bit 8 is set to 0.

SYSTem

The SYSTem subsystem returns the error numbers and error messages in the error queue of a switchbox, and returns the types and descriptions of modules (cards) in a switchbox.

Subsystem Syntax

```
SYSTem
:CDescription? <number>
:CPON <number | ALL>
:CTYPe? <number>
:ERRor?
```

:CDescription?

SYSTem:CDescription? <number> returns the description of a selected module (card) in a switchbox.

Parameters

Parameter Name	Parameter Type	Range of Values
<i>number</i>	numeric	1-99

Comments

- **4 X 4 Relay Matrix Module Description:**
The SYSTem:CDescription? <number> command returns:

4 X 4 Relay Matrix

Example

Reading the Description of a Card#1 Module

```
SYST:CDES? 1 Return the description
```

:CPON

SYSTem:CPON <number | ALL> sets the selected module (card) in a switchbox to its power-on state.

Parameters

Parameter Name	Parameter Type	Range of Values
<i>number</i>	numeric	1-99

Comments

- **Matrix Module Power-On State:** The power-on state is all channels (relays) open. Note that *RST opens all channels of all modules in a switchbox, while SYSTem:CPON <number> opens the channels in only the module (card) specified in the command.

Example

Setting Card #1 Module to its Power-On State

```
SYST:CPON 1 Sets module #1 to power-on state
```

:CTYPe? **SYSTem:CTYPe? <number>** returns the module (card) type of a selected module in a switchbox.

Parameters

Parameter Name	Parameter Type	Range of Values
<i>number</i>	numeric	1-99

Comments

- **4 X 4 Relay Matrix Module Model Number:** The SYSTem:CTYPe? <number> command returns:

HEWLETT-PACKARD , E1361A , 0 , A . 01 . 00

where the 0 after E1361A is the module serial number (always 0) and A.01.00 is an example of the module revision code number.

Example Reading the Model Number of a Card#1 Module

SYST:CTYP? 1 *Return the model number*

ERRor?

SYSTem:ERRor? returns the error numbers and corresponding error messages in the error queue of a switchbox. See Appendix C for a listing of some switchbox error numbers and messages.

Comments

- **Error Numbers/Messages in the Error Queue:** Each error generated by a switchbox stores an error number and corresponding error message in the error queue. The error message can be up to 255 characters long.
- **Clearing the Error Queue:** An error number/message is removed from the queue each time the SYSTem:ERRor? command is sent. The errors are cleared first-in, first-out. When the queue is empty, each following SYSTem:ERRor? command returns 0, "No error". To clear all error numbers/messages in the queue, execute the *CLS command.
- **Maximum Error Numbers/Messages in the Error Queue:** The queue holds a maximum of 30 error numbers/messages for each switchbox. If the queue overflows, the last error number/message in the queue is replaced by -350, "Too many errors". The least recent error numbers/messages remain in the queue and the most recent are discarded.

Example Reading the Error Queue

SYST:ERR? *Query the error queue*

TRIGger

The TRIGger command subsystem controls the triggering operation of relay matrix modules in a switchbox.

Subsystem Syntax

```
TRIGger  
[:IMMediate]  
:SOURce BUS | EXTernal | HOLD | IMMEDIATE  
:SOURce?
```

[:IMMediate]

TRIGger[:IMMediate] causes a trigger event to occur when the defined trigger source is TRIGger:SOURce BUS or TRIGger:SOURce HOLD.

Comments

- **Executing the TRIGger[:IMMediate] Command:** A channel list must be defined with [ROUTE:]SCAN <channel_list> and an INITiate[:IMMediate] command must be executed before TRIGger[:IMMediate] will execute.
- **BUS or HOLD Source Remains:** If selected, the TRIGger:SOURce BUS or TRIGger:SOURce HOLD commands remain in effect after triggering a switchbox with the TRIGger[:IMMediate] command.
- **Related Commands:** INITiate, [ROUTE:]SCAN

Example

Advancing Scan Using TRIGger Command

This example uses the TRIGger command to advance the scan of a single-module switchbox from channel 00 through 03. Since TRIGger:SOURce HOLD is set, the scan is advanced one channel each time TRIGger is executed.

TRIG:SOUR HOLD	<i>Sets trigger source to HOLD</i>
SCAN (@100:103)	<i>Defines channel list</i>
INIT	<i>Begin scan, close channel 00</i>
loop statement	<i>Start count loop</i>
TRIG	<i>Advance scan to next channel</i>
increment loop	<i>Increment loop count</i>

:SOURce TRIGger:SOURce BUS | EXTernal | HOLD | IMMEDIATE specifies the trigger source to advance the *channel list* during scanning.

Parameters

Parameter Name	Parameter Type	Range of Values
BUS	discrete	*TRG or GET command
EXTernal	discrete	"Event In" port
HOLD	discrete	Hold triggering
IMMEDIATE	discrete	Immediate triggering

Comments

- **Enabling the Trigger Source:** The TRIGger:SOURce command only selects the trigger source. The INITiate[:IMMEDIATE] command enables the trigger source.
- **Using the TRIG Command:** You can use TRIGger[:IMMEDIATE] to advance the scan when TRIGger:SOURce BUS or TRIGger:SOURce HOLD is selected.
- **Using External Trigger Inputs:** With TRIGger:SOURce EXTernal selected, only one switchbox at a time can use the external trigger input at the Agilent E1300B/E1301B Mainframe "Event In" port. The trigger input is assigned to the first switchbox that requested the external trigger source (with a TRIGger:SOURce EXTernal command).
- **Assigning External Trigger:** A switchbox assigned with TRIGger:SOURce EXTernal remains assigned to that source until the switchbox trigger source is changed to BUS, HOLD, or IMMEDIATE. When the source is changed, the external trigger source is available to the next switchbox which requests it (with a TRIGger:SOURce EXTernal command). If a switchbox requests an external trigger input already assigned to another switchbox an error is generated.
- **Using Bus Triggers:** To trigger the switchbox with TRIGger:SOURce BUS selected, use the IEEE 488.2 common command *TRG or the GPIB Group Execute Trigger (GET) command.
- **Trig Out Port Shared by Switchboxes:** See the OUTPut command.
- **Related Commands:** ABORt, [ROUTE:]SCAN, TRIGger
- ***RST Condition:** TRIGger:SOURce IMMEDIATE

Examples Scanning Using External Triggers

This example uses external triggering (TRIG:SOUR EXT) to scan channels 00 through 03 of a single-module switchbox. The trigger source to advance the scan is the input to the "Event In" on an Agilent E1300B/E1301B mainframe. When INIT is executed, the scan is started and channel 00 is closed. Then each trigger received at the "Event In" advances the scan to the next channel.

TRIG:SOUR EXT	<i>Select external triggering</i>
SCAN (@100:103)	<i>Scan channels 00 through 03</i>
INIT	<i>Begin scan, close channel 00</i>
trigger externally	<i>Advance scan to next channel</i>

Scanning Using Bus Triggers

This example uses bus triggering (TRIG:SOUR BUS) to scan channels 00 through 03 of a single-module switchbox. The trigger source to advance the scan is the *TRG command (as set with TRIGger:SOURce BUS). When INIT is executed, the scan is started and channel 00 is closed. Then, each *TRG command advances the scan to the next channel.

TRIG:SOUR BUS	<i>Select interface (bus) triggering</i>
SCAN (@100:103)	<i>Scan channels 00 through 03</i>
INIT	<i>Start scan, close channel 00</i>
loop statement	<i>Loop to scan all channels</i>
*TRG	<i>Advance scan using bus triggering</i>
increment loop	<i>Increment loop count</i>

:SOURce? **TRIGger:SOURce?** returns the current trigger source for the switchbox. Command returns BUS, EXT, HOLD, or IMM for sources BUS, EXTERNAL, HOLD, or IMMEDIATE, respectively.

Example Query Trigger Source

This example sets external triggering and queries the trigger source. Since external triggering is set, TRIG:SOUR? returns EXT.

TRIG:SOUR EXT	<i>Set external trigger source</i>
TRIG:SOUR?	<i>Query trigger source</i>

IEEE 488.2 Common Commands

The following table lists the IEEE 488.2 Common (*) Commands that apply to the relay matrix module. The operation of some of these commands is described in Chapter 4 of this manual. For more information on Common Commands, refer to the *Agilent 75000 Series B Mainframe* (Agilent Model Number E1300/E1301) *User's Manual* or the ANSI/IEEE Standard 488.2-1987.

Command	Title	Description
*IDN? *RST *TST?	Identification Reset Self-Test	Returns identification string of the switchbox. Opens all channels, and invalidates current channel list for scanning. Sets ARM:COUN 1, TRIG:SOUR IMM, and INIT:CONT OFF. Always returns 0.
*OPC *OPC? *WAI	Operation Complete Operation Complete Query Wait to Complete	See note below See note below See note below
*CLS *ESE *ESE? *ESR? *SRE *SRE? *STB?	Clear status Event status enable Event status enable query Event status register query Service request enable Service request enable query Read status byte query	Clears all status registers (see STATus:OPERation[:EVENT]?) See note below See note below See note below Enables status register bits (see Chapter 4 for operation) See note below See note below
*TRG	Trigger	Triggers the switchbox to advance the scan when scan is enabled and trigger source is TRIGger:SOURce BUS
*RCL *SAV	Recall instrument state Store instrument state	See note below See note below
<p>Note: These commands apply to many instruments and are not documented in detail here. See the <i>Agilent 75000 Series B E1300/E1301 Mainframe User's Manual</i>, the <i>Agilent E1405A Command Module Manual</i> or the ANSI/IEEE Standard 488.2-1987 for more information.</p>		

Command Quick Reference

The following tables summarize SCPI and IEEE 488.2 Common (*) Commands for relay matrix modules used in a switchbox.

SCPI Commands Quick Reference

Command	Description
ABORt	Abort a scan in progress.
ARM :COUNT <number> MIN MAX :COUNT? [MIN MAX]	Multiple scans per INIT command. Query number of scans.
DISPlay :MONitor:CARD <number / AUTO> :MONitor[:STATe] <boolean>	Selects module to be monitored. Selects monitor mode.
INITiate :CONTinuous <mode> :CONTinuous? [:IMMEDIATE]	Enables/disables continuous scanning. Query continuous scan state. Starts a scanning cycle.
OUTPut [:STATe] <state> [STATe]?	Enables/disables "Trig Out" pulse. Query port enable state.
[ROUte:] CLOSe <channel_list> CLOSe? <channel_list> OPEN <channel_list> OPEN? <channel_list> SCAN <channel_list> SCAN:MODE NONE VOLT	Close channel(s). Query channel(s) closed. Open channel(s). Query channel(s) opened. Define channels for scanning. Sets scan mode.
STATus :OPERation:ENABLE :OPERation[:EVENT]?	Enables the Operation Status Register to set a bit in the Status Register. Returns status of Operation Status Register.
SYSTEM :CDEscription? <number> :CPON <number ALL> :CTYPE? <number> :ERRor?	Returns description of module in a switchbox. Sets specified module to its power-on state. Returns the module type. Returns error number/message in a switchbox Error Queue.
TRIGger [:IMMEDIATE] :SOURce BUS :SOURce EXTernal :SOURce HOLD :SOURce IMMEDIATE :SOURce?	Causes a trigger to occur. Trigger source is *TRG. Trigger source is "Event In". Hold off triggering. Continuous (internal) triggers. Query scan trigger source.

IEEE 488.2 Common Commands Quick Reference

Command	Title	Description
*RST	Reset	Opens all channels, and invalidates current channel list for scanning. Sets ARM:COUN 1, TRIG:SOUR IMM, and INIT:CONT OFF
*TRG	Bus Trigger	When scan is enabled and trigger source is TRIG:SOUR BUS, use the *TRG command to trigger the switchbox to advance the scan.
*TST?	Self-Test	Always returns 0.

Appendix A

Agilent E1361A Relay Matrix Specifications

Maximum Input Voltage:

Hi to Lo	Any term. to chassis
250VDC	250 VDC
250VAC rms	250VAC rms
354VACpeak	354VACpeak

Maximum Current:

Per Channel: 40WDC or 40VA ACrms

Maximum Power:

Per Channel: 40WDC or 40VA AC
Per Module: 320WDC or 320VA AC

Thermal Offset:

<14 μ V differential per path

Closed Channel Resistance:

<1.5 Ω /contact (typical)
<3.5 Ω at end of relay life

Insulation Resistance:

>10⁷ Ω at \geq 40°C, 65% RH
>10⁸ Ω at \geq 25°C, 40% RH

Bandwidth: -3dB at 10 MHz
(50 Ω source and load)

Crosstalk, Channel to Channel (typical):

\leq 100kHz: \leq 80dB
 \leq 10Mhz: \leq 30dB

Capacitance:

H to L: <150pF*
H to H: <20pF
L to L: <20pF
H or L to Chassis: <150pF
*all contacts closed

Net Weight: 0.7 kg

Insertion Loss:

\leq 100kHz: <0.1dB
 \leq 10MHz: <3.0dB

Relay Life (typical):

No Load: >10⁶ operations
Max. Load: >10⁵ operations

Terminals: Screw type, removable. Max. Wire Size, 16AWG

Module Size/Device Type:

VXI B-Size, Register-based

Connectors used: P1

No. Slots: 1

VXIbus Interface Capability:

Interrupter, D16

Interrupt Level: 1-7 selectable

Power Requirements:

Voltage:	+5	+12
Peak module current, IPM (A):	0.10	0.24
Dynamic module current, IDM (A)	0.01	0.01

Watts/slot: 1.0

Cooling/slot:

0.02 mm H₂O @ 0.10 liters/sec

Humidity: 65% 0 to 40°C

Operating Temperature: 0 to 55 °C

Storage Temperature: -40 to +75°C

EMC, RFI Safety: meets FTZ 1046/1984, CSA 556B, IEC 348, UL 1244

Relay Life

Electromechanical relays are subject to normal wear-out. Relay life depends on several factors. The effects of loading and switching frequency are briefly discussed below:

Relay Load. In general, higher power switching reduces relay life. In addition, capacitive/inductive loads and high inrush currents (for example, turning on a lamp or starting a motor) reduces relay life. *Exceeding specified maximum inputs can cause catastrophic failure.*

Switching Frequency. Relay contacts heat up when switched. As the switching frequency increases, the contacts have less time to dissipate heat. The resulting increase in contact temperature also reduces relay life.

End-of-Life Detection

A preventive maintenance routine can prevent problems caused by unexpected relay failure. The end of the life of the relay can be determined by using one or more of the three methods described below. The best method (or combination of methods), as well as the failure criteria, depends on the application in which the relay is used.

Contact Resistance. As the relay begins to wear out, its contact resistance increases. When the resistance exceeds a predetermined value, the relay should be replaced.

Stability of Contact Resistance. The stability of the contact resistance decreases with age. Using this method, the contact resistance is measured several (5-10) times, and the variance of the measurements is determined. An increase in the variance indicates deteriorating performance.

Number of Operations. Relays can be replaced after a predetermined number of contact closures. However, this method requires knowledge of the applied load and life specifications for the applied load.

Replacement Strategy

The replacement strategy depends on the application. If some relays are used more often, or at a higher load, than the others, the relays can be individually replaced as needed. If all the relays see similar loads and switching frequencies, the entire circuit board can be replaced when the end of relay life approaches. The sensitivity of the application should be weighed against the cost of replacing relays with some useful life remaining.

Note

Relays that wear out normally or fail due to misuse should not be considered defective and are not covered by the product's warranty.

Appendix B

Agilent E1361A Relay Matrix Registers

Register Definitions

The E1361A 4 X 4 Relay Matrix is a register-based slave device. See Figure B-1 for register definitions.

ID Register

b+00₁₆	15	14	13	12	11	10	9	8	7	6	5	4	3	2	1	0
Write	Undefined								Undefined							
Read*	RegBas		A16		Manufacturer ID											

* Returns FFFF₁₆ = A16 only Register-based

Device Type Register

b+02₁₆	15	14	13	12	11	10	9	8	7	6	5	4	3	2	1	0
Write	Undefined															
Read*	1 (A16 only)				Module ID Code											

*Returns FF24₁₆

Status/Control Register

b+04₁₆	15	14	13	12	11	10	9	8	7	6	5	4	3	2	1	0
Write*	Undefined															R
Read**	FF ₁₆							B	7F ₁₆							

* R is matrix reset (all channels open); ** Status "busy" is low true in bit #7 (FF7F₁₆)

Channel Enable Register

b+08₁₆	15	14	13	12	11	10	9	8	7	6	5	4	3	2	1	0
Write*	33	23	13	03	32	22	12	02	31	21	11	01	30	20	10	00
Read	Always returns FFFF ₁₆															

* Write "1" to close channel, "0" to open channel. First number in Write is row, second is column (e.g., for bit #11, 3 = row 3 and 2 = column 2). All combinations are allowed (all rows and columns can be connected).

Figure B-1. Relay Matrix - Register Definitions

Addressing the Registers

To read or write to specific registers, you must use the register address. Since the addresses for Agilent 75000 Series B or Series C plug-in modules are A00 through A15, use the VME A16 mnemonic for the address space. The address space within the mainframe/command module memory map depends on the mainframe/command module used. For example, the address of the Agilent E1300B/E1301B Mainframe starts at $1F0000_{16}$.

For the Agilent E1300/E1301, the A16 space is divided so modules are addressed only at locations beginning with $C000_{16}$ within A16. Each module is allocated 64 register addresses (40_{16}). The module base address is related to the logical address set by the logical address switch (LADDR) on the module:

$$\text{base address}_{16} = (\text{logical address}_{16}) * 40_{16} + C000_{16}$$

For the relay matrix, the factory-set logical address is 120 (78_{16}), so the base address = $(78_{16}) * (40_{16}) + C000_{16} = DE00_{16}$. Then, for example, to address the Status/Control Register of a relay matrix in an Agilent E1300B/E1301B, the register address = $[A16 \text{ location}]_{16} + [\text{base address}]_{16} + [\text{register offset}]_{16} = 1F0000_{16} + DE00_{16} + 04_{16} = 1FDE04_{16}$.

Reading the Registers

You can read the following relay matrix registers:

- ID Register (base + 00_{16})
- Device Type Register (base + 02_{16})
- Status/Control Register (base + 04_{16})
- Channel Enable Register (base + 08_{16})

ID/Device Type Registers

For the relay matrix, a read of the ID Register (address base + 00_{16}) returns $FFFF_{16}$ since the matrix is manufactured by Agilent and is an A16 only, register-based device. The Device Type Register (base + 02_{16}) returns $FF24_{16}$.

Status/Control Register

Each relay requires about 15 msec execution time (close to open or open to close) during which time the matrix is "busy". A read of the Status/Control Register (base + 04_{16}) returns $FFFF_{16}$ when the matrix is not busy or returns $FF7F_{16}$ (bit 7 is low-true) when the matrix is busy.

Channel Enable Register

A read of the Channel Enable Register (base + 08_{16}) always returns $FFFF_{16}$, regardless of the channel states.

Writing to the Registers

You can write to the following relay matrix registers:

- Status/Control Register (base + 04₁₆)
- Channel Enable Register (base + 08₁₆)

Status/Control Register

The only write allowed to the Status/Control Register (base + 04₁₆) is to bit 0. Writing a "1" to bit 0 resets the matrix (all channels open).

Note

All relays are latching and will remain in the last state during power down. At power-up or when the module is reset, all relays open. Any combination of channel open or closed states is allowed.

Channel Enable Register

Writes to the Channel Enable Register (base + 08₁₆) enable you to open or close the desired channel (see Figure B-1). For example, write a "1" to bit 2 of the Channel Enable Register to close channel 20 (row 2, column 0). Or, write a "0" to bit 14 of the register to open channel 23 (row 2, column 3).

Appendix C

Agilent E1361A Relay Matrix Error Messages

Table C-1 lists the error messages associated with the relay matrix modules programmed by SCPI. See the appropriate mainframe manual for a complete list of error messages.

Table C-1. 4 X 4 Relay Matrix Module Error Messages

No.	Title	Potential Cause(s)
-211	Trigger ignored	Trigger received when scan not enabled. Trigger received after scan complete. Trigger too fast.
-213	Init Ignored	Attempting to execute an INIT command when a scan is already in progress.
-224	Illegal parameter value	Attempting to execute a command with a parameter not applicable to the command.
1500	External trigger source already allocated	Assigning an external trigger source to a switchbox when the trigger source has already been assigned to another switchbox.
2000	Invalid card number	Addressing a module (card) in a switchbox that is not part of the switchbox.
2001	Invalid channel number	Attempting to address a channel of a module in a switchbox that is not supported by the module (e.g., channel 99 of a multiplexer module).
2006	Command not supported on this card	Sending a command to a module (card) in a switchbox that is unsupported by the module.
2008	Scan list not initialized	Executing a scan without the INIT command.
2009	Too many channels in channel list	Attempting to address more channels than available in the switchbox.
2012	Invalid Channel Range	Invalid channel(s) specified in SCAN <i><channel_list></i> command. Attempting to begin scanning when no valid channel list is defined.
2600	Function not supported on this card	Sending a command to a module (card) in a switchbox that is not supported by the module or switchbox.
2601	Channel list required	Sending a command requiring a channel list without the channel list.

- *CLS, 59
- *ESE, 59
- *ESE?, 59
- *ESR?, 59
- *IDN?, 59
- *OPC, 59
- *OPC?, 59
- *RCL, 35, 59
- *RST, 35, 59 - 60
- *SAV, 35, 59
- *SRE, 34, 59
- *SRE?, 59
- *STB?, 34, 59
- *TRG, 59 - 60
- *TST?, 59 - 60
- *WAI, 59

A

- Abbreviated Commands, 38
- ABORt, 41
- Addressing
 - channels, 13 - 14
 - registers, 64
 - switchbox, 13
- ARM Subsystem, 42 - 43
- ARM:COUNT, 30, 42
- ARM:COUNT?, 43

B

- Backplane Connector, 23
- Basic Operation, 12
- Block Diagram, 12
- Boolean Parameters, 39
- Bus Triggers, 57 - 58

C

- Card Numbers, 14
- Cautions, 17 - 18
- Certification, 5
- Changing
 - components, 22 - 23
 - IRQ jumper position, 22 - 23
 - logical address setting, 22 - 23
- Channel
 - address, 13 - 14
 - closing, 27, 49
 - closure time, 13
 - enable register, 63 - 65
 - jumpers, 22 - 23
 - lists, 14 - 15, 49 - 51
 - monitor state, 44
 - numbers, 14
 - opening, 50
 - query state, 27, 50 - 51
 - ranges, 14 - 15
 - relays, 12
 - scanning, 29, 51
 - scanning commands, 29 - 30
 - switching, 25, 27
 - wiring insulation, 17
- Closing
 - channels, 27, 49
 - relays, 13
- Command
 - in square brackets ([]), 38 - 39
 - linking, 40
 - quick reference, 60
 - reference, 37 - 60
 - SCPI command reference, 40
 - types of, 37
- Comment sheet, reader, 9

C (continued)

Common (*) Commands, 59

- *CLS, 59
- *ESE, 59
- *ESE?, 59
- *ESR?, 59
- *IDN?, 59
- *OPC, 59
- *OPC?, 59
- *RCL, 35, 59
- *RST, 35, 59 - 60
- *SAV, 35, 59
- *SRE, 34, 59
- *SRE?, 59
- *STB?, 34, 59
- *TRG, 59 - 60
- *TST?, 59 - 60
- *WAI, 59
- format, 37
- linking with SCPI, 40
- quick reference, 59

Components, changing, 22 - 23

Configuration

- 4 X 12 matrix, 21
- 4 X 4 matrix, 13, 20, 26
- 8 X 1 matrix, 22
- dual 4 X 2 matrix, 13, 20 - 21, 26 - 27
- high voltage matrix, 22
- larger matrixes, 21
- switchbox, 14
- typical matrix, 13, 20

Conformity, declaration, 7

Contact Resistance, relays, 62

Continuous Scanning Cycles, 46

Cross Points, 12

D

Declaration of Conformity, 7

Description of Relay Matrix, 11

Device Type Register, 63 - 64

Discrete Parameters, 39

DISPlay Subsystem, 44 - 45

DISPlay:MONitor:CARD, 44

DISPlay:MONitor[:STATe], 45

Documentation history, 6

Dual 4 X 2 Matrix, 13, 20 - 21, 26 - 27

E

Error

- messages, 67 - 68
- numbers, 67 - 68
- queue, 55
- register, 35
- responses, 35

Examples

- scan complete interrupt, 34
- scanning using bus triggers, 58
- scanning using external triggers, 58
- scanning using Trig Out & Event In ports, 33
- scanning with external device, 32

External Triggers, 57 - 58

F

Front Panel Pin-out, 24

Fuses, 22 - 23

H

High-Voltage Matrix, 22

I

ID Register, 63 - 64

IEEE 488.2 Commands

See Common (*) Commands

Implied Commands, 38

Initial Operation, 15

INITiate Subsystem, 46 - 47

INITiate:CONTinuous, 30, 46

INITiate:CONTinuous?, 47

INITiate[:IMMediate], 47

Inputs, connecting user, 18, 24

Instrument Definition, 11

Interrupt Priority Jumpers, 22 - 23

J

Jumpers, 22 - 23

L

Linking Commands, 40

Logical Address, 14

- changing, 22 - 23
- switchbox, 14

M

Multiple-Module Switchbox
card numbers, 14
channel ranges, 14

N

Numeric Parameters, 39

O

Opening
channels, 50
relays, 13
Operation
initial, 15
limits, 13, 18, 61 - 62
scanning, 51
Operation Status Register, 53
scan complete bit, 34, 53
Optional Parameters, 39
OUTPut Subsystem, 48
OUTPut[:STATe], 48
OUTPut[:STATe]?, 48

P

Parameters, 38 - 39
Pin-out Diagram, 24
Programming the Relay Matrix, 13

Q

Query
channel states, 27, 50 - 51
error queue, 55
error register, 35
scanning states, 47
trig out port, 48
trigger source, 58

R

Reader Comment Sheet, 9
Reading Registers, 64
Recalling States, 35

Registers

addressing, 64
channel enable, 63 - 65
device type, 63 - 64
manufacturer identification, 63 - 64
reading, 64
status/control, 63 - 65
writing to, 65

Relays

closing, 13
end-of-life detection, 62
life expectancy, 62
opening, 13
replacement of, 62

Reset State, 12

Root Command, 38

[ROUte:] Subsystem, 49 - 52

[ROUte:]CLOSe, 49

[ROUte:]CLOSe?, 50

[ROUte:]OPeN, 50

[ROUte:]OPeN?, 51

[ROUte:]SCAN, 30, 51

[ROUte:]SCAN:MODE, 30, 52

[ROUte:]SCAN:MODE?, 52

S

Safety warnings, 6

Scan Complete Bit, 34

Scan Rate, maximum, 13

Scanning

advancing, 30
channels, 29, 51
continuous scanning cycles, 46
cycle, 47
cycles, 30, 42 - 43, 46
operation, 51
query state, 47
SCPI commands, 29 - 30
stopping in progress, 41
trigger sources, 29, 31, 57 - 58
using bus triggers, 58
using external triggers, 58
using Trig Out & Event In ports, 33
with external instruments, 29, 32

SCPI

error responses, 35
programming, 13

S (continued)

SCPI Commands

- abbreviated, 38
 - ABORt subsystem, 41
 - ARM subsystem, 42 - 43
 - DISPlay subsystem, 44 - 45
 - format, 38
 - implied, 38
 - in square brackets ([]), 38 - 39
 - INITiate subsystem, 46 - 47
 - linking with common, 40
 - OUTPut subsystem, 48
 - parameters, 38 - 39
 - quick reference, 60
 - reference, 40
 - root command, 38
 - [ROUte:] subsystem, 49 - 52
 - scanning commands, 29 - 30
 - second level, 38
 - separator, 38
 - specifying, 13
 - STATus subsystem, 53
 - SYSTem subsystem, 54 - 55
 - third level, 38
 - trigger sources, 29, 31, 57 - 58
 - TRIGger subsystem, 56 - 58
- Second Level Command, 38
- Single-Module Switchbox, channel ranges, 14
- Specifications, 61 - 62
- Specifying SCPI Commands, 13
- Starting Scanning Cycles, 47
- Status Register, 53
- STATus Subsystem, 53
- Status/Control Register, 63 - 65
- STATus:OPERation:ENABLE, 34, 53
- STATus:OPERation[:EVENT]?, 53
- Stopping
- a Scan, 41
 - continuous scan, 46
 - scanning cycles, 47
- Storing States, 35
- Subsystem
- ABORt, 41
 - ARM, 42 - 43
 - DISPlay, 44 - 45
 - INITiate, 46 - 47
 - OUTPut, 48
 - [ROUte:], 49 - 52
 - STATus, 53
 - SYSTem, 54 - 55
 - TRIGger, 56 - 58

Switchbox

- addressing, 13
- configuration, 13 - 14
- continuous scanning, 46
- logical addresses, 14
- monitor channel state, 44
- multiple-module card numbers, 14
- multiple-module channel ranges, 14
- recalling states, 35
- response to *RST, 35
- single-module channel ranges, 14
- storing states, 35

Switching

- 4 X 4 example, 26
- channels, 25, 27
- dual 4 X 2 example, 26 - 27

SYSTem Subsystem, 54 - 55

SYSTem:CDEscription, 54

SYSTem:CPON, 54

SYSTem:CTYPe?, 55

SYSTem:ERRor?, 35, 55

T

Terminal Block

- matrix connections, 18
- not using, 24
- terminal connectors, 18
- wiring, 19

Third Level Command, 38

Trig Out Port, 48

Trigger Sources Used, 29, 31, 57 - 58

TRIGger Subsystem, 56 - 58

TRIGger:SOURce, 29 - 31, 57 - 58

TRIGger:SOURce?, 58

TRIGger[:IMMediate], 56

W

WARNINGS, 6, 17

Warranty, 5

Wiring the Terminal Block, 19

Writing to Registers, 65